

Seasons and Moon Phases Kit Curriculum

Developed by Clark Planetarium

With support from iSEE Teacher Resource Program



Contents

Reason for the Seasons:	3
Alignment to Utah 6 th Grade SEEd Standards	4
Materials Needed:.....	5
Teacher Background:	6
Setup and Preparation:	9
Procedure:	13
Additional Seasons Activities	22
Seasons: Angle of Incidence	22
Seasons: Constellations	28
Seasons: Reason for the Seasons “Short Version”	34
Seasons: Tilt, Daylight and Seasons.....	39
Phases of the Moon:	42
Alignment to Utah 6 th Grade SEEd Standards	43
Materials Needed:.....	44
Teacher Background:	45
Setup and Preparation:	47
Procedure:	48
Eclipses:	51
Alignment to Utah 6 th Grade SEEd Standards	52
Teacher Background:	53
Setup and Preparation:	53
Materials Needed:.....	54
Procedure:	55

Reason for the Seasons

Estimated setup time: 20 minutes

Estimated activity time: 90-120 minutes

Description:

This hands-on activity will challenge students' common misconceptions by using observation, data collection, analysis and comparison to allow the students to discover the real reason behind the seasons. Students will work together in small scientific groups to research and collect data and convene with the greater scientific community (classroom) to share data and draw conclusions. Students will:

- Measure the amount of sunlight at specific locations on the globes
- Estimate the height of the noon Sun
- Estimate the number of hours of daylight various parts of the Earth receive at different times of the year

Student Performance Outline:

- Phenomenon – The Sun's height at local noon and the hours of daylight change over a year and those changes follow a pattern that repeats each year.
- Individual Student Performance
 - Complete the SUNRISE-SUNSET AND TEMPERATURE DATA FOR SALT LAKE CITY, UTAH worksheet and make a bar-graph using the Daylight-Temperature Comparison worksheet.
- Group Performance
 - Observe the changing height of the Sun (at local noon) throughout the year using the Sun Altitude2 PowerPoint or astronomy software
 - Develop and use a model of the Sun-Earth-Moon system to describe the yearly cyclic patterns of the changing Sun height and of the changing hours of daylight and how light intensity in the Northern and Southern Hemispheres varies over a year.
 - Construct an explanation supported by evidence for how Earth's tilt in combination with its motion around the Sun causes Utah to experience different seasons over a year.
- Individual Performance
 - Write in your journal your argument for why your evidence supports your group's explanation for the cause of the seasons
- Group discussion

Alignment to Utah 6th Grade SEEd Standards

Strand 6.1: Structure and Motion within the Solar System

The solar system consists of the Sun, planets, and other objects within Sun's gravitational influence. Gravity is the force of attraction between masses. The Sun-Earth-Moon system provides an opportunity to study interactions between objects in the solar system that influence phenomena observed from Earth. Scientists use data from many sources to determine the scale and properties of objects in our solar system.

Standard 6.1.1

Develop and use a model of the Sun-Earth-Moon system to describe the cyclic patterns of lunar phases, eclipses of the Sun and Moon, and seasons. Examples of models could be physical, graphical, or conceptual.

Scientific and Engineering Practices Utilized:

- Asking questions or defining problems
- Developing and using models
- Analyzing and interpreting data
- Using mathematics and computational thinking
- Constructing explanations and designing solutions
- Obtaining, evaluating, and communicating information
- Engaging in argument from evidence

Crosscutting Concepts:

- Patterns
- Cause and effect: mechanism and explanation
- Scale, proportion, and quantity

Materials Needed:

- Provided in kit:
 - 4 Earth globes prepared with solar energy collectors and pegs
 - 6 digital multi-meters (4 used to measure solar cell output, 2 spares); these units measure the electricity output of the solar cells
 - 4 500 watt lamps with stands
 - 2 power strips
 - 1 12-gauge extension cord
 - 1 ruler, measuring tape or 6 ft. string
 - master copy of student worksheet
- Additional resources needed:
 - Darkened multipurpose room or classroom with adequate room to move 4 groups of 4-8 students around 4 stations (area of about 16 ft. in diameter)
 - 1 (or more) electrical outlet(s)
 - 5 desks or small tables (must be level, the same height, and large enough to hold all of the station materials.)
 - pencil/pen (one for each student)
 - copies of student worksheets (one for each student)
 - 1 roll masking tape
 - 1 projection screen - *optional*
 - 1 overhead projector – *optional*
 - 1 overhead copy of the Worksheet (for the overhead projector: classroom analysis and comparison) - *optional*

Teacher Background:

Earth rotates on its axis once a day. Earth also orbits, or revolves, around the Sun once each year. Earth's rotational axis is tilted by about 23.4° relative to its orbit around the Sun. The axis points in a nearly constant direction as Earth circles the Sun. This is evidenced by the northern axis pointing toward Polaris, the North Star. As a result of Earth's axis tilt and its motion around the Sun, many locations on Earth experience seasons.

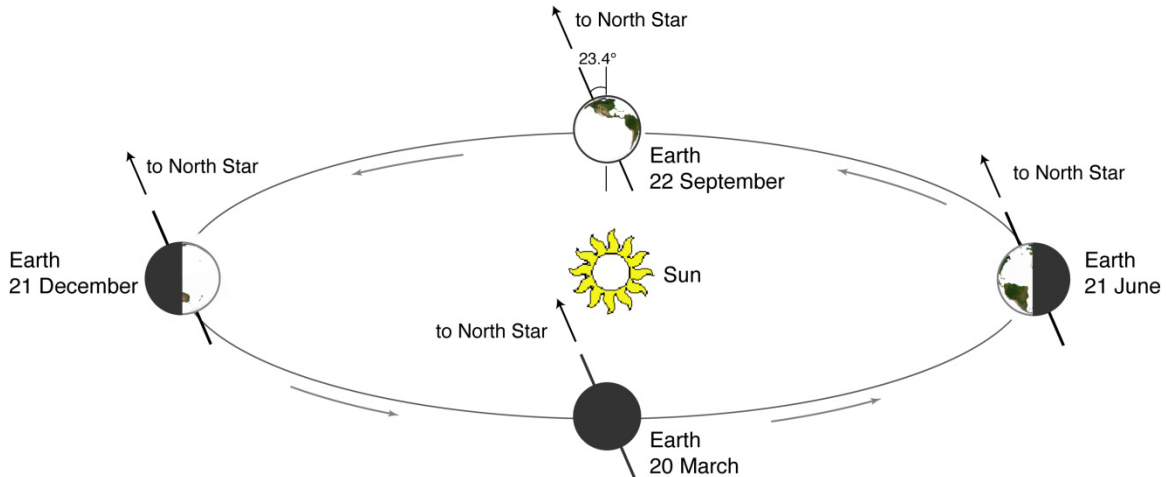

Earth Orbit Viewed from the Side

Earth's position in its orbit on the first day of winter, spring, summer, and fall in the Northern Hemisphere. The seasons are reversed in the Southern Hemisphere. Note: the diagram is not to scale and the orbit is viewed from the side. If the orbit were viewed from above, it would appear to be a circle.

Since Earth's tilt is constant, (the North Pole is always pointed toward the North Star), it is best to get into the habit of talking not about tilt, but about "**leaning**" toward or away from the Sun. This helps students who wind up thinking that our axis wobbles back and forth each year.

When it is summer in Utah, Earth's northern axis is **leaning toward** the Sun. At this time, the Sun is high overhead at noon and we have more hours of daylight than of darkness. The concentrated rays of sunlight have more time to warm this part of Earth, so we experience warmer weather.

If Earth were actually the size depicted in the diagram, the Sun would be a sphere 2 meters (6.8 feet) in diameter, and would be 223 meters (730 feet) away.

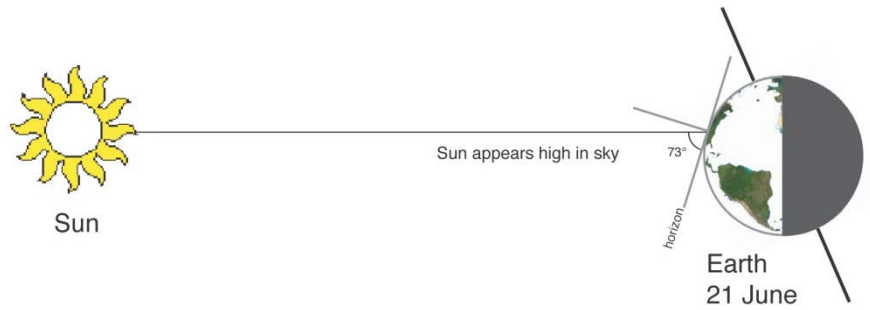

During Utah's winter, the northern axis is **leaning away** from the Sun. At this time of year, the Sun is low in the sky at noon and the length of day is much shorter than the length of night. When the Sun is low in the sky, the Sun's rays are spread out over a larger area and can't warm the ground as effectively. With fewer hours of daylight and less efficient heating, we experience colder temperatures even though the Sun is still shining bright.

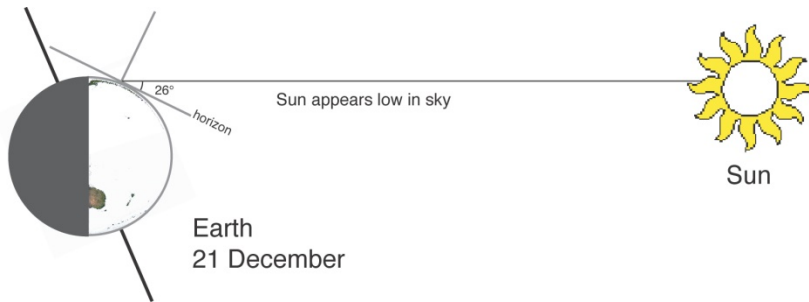

As Earth continues to move around the Sun, there is an increase in the hours of daylight and the Sun climbs higher in the sky. Winter changes to spring and then back to summer as we complete one full journey around the Sun.

Common Misconceptions:

Many students hold the misconception that the changing seasons are a result of the change in distance between Earth and Sun. Two possible sources for this misconception are:

- Misleading text book illustrations
 - Most text books use illustrations that exaggerate the shape of Earth's orbit around the Sun by tilting the perspective of the illustration (like the orbit illustration on page 4). This fuels the misunderstanding that the orbit is very elliptical, bringing Earth much closer to the Sun at certain times of the year.
 - While Earth's orbit is an ellipse, it differs from being a perfect circle by only 1.67%. In fact, Earth is closest to the Sun on or near January 4 and farthest from the Sun on or near July 4. Utah's weather on these dates is opposite of what would be expected under this common misconception. This small change in distance accounts for only a few degrees of temperature change, thus, the elliptical nature of Earth's orbit around the Sun does not vary the distance to the Sun enough to make any noticeable difference in the seasons.

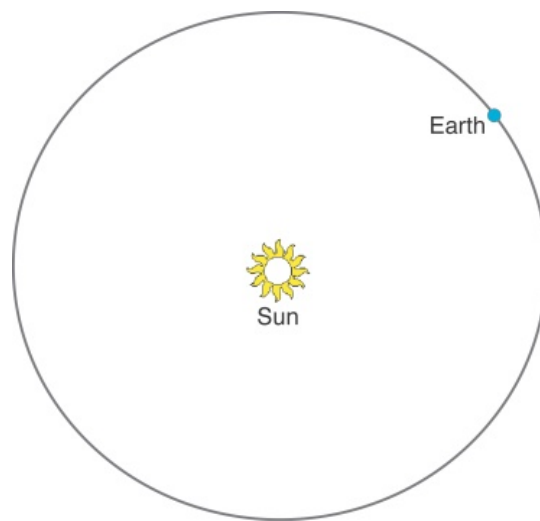

Earth's orbit viewed from above, size of Sun and Earth not to scale

- Personal experience of warmer temperatures closer to a heat source:
 - The other great misunderstanding is that Earth experiences warmer temperatures in summer because it is closer to the Sun. Many students will have felt increased heat when they have moved closer to a heat source, like a campfire, fireplace, or stove. When someone is very close to a heat source, a small change in distance can result in a noticeable change in received heat. However, Earth is far from the Sun (if the Sun were a ball 6 inches in diameter, Earth would be about the size of the head on a pin and would be about 50 feet away from the Sun), so small changes in distance would have little effect. Example: If someone were already standing 25 feet from a fireplace, would they feel significantly more heat if they moved 6 inches closer? No.

Setup and Preparation:

The activity globes have pegs and solar energy collectors glued to the surface in key locations. The solar energy collectors convert light into electricity; more direct light produces more electricity. The electricity is measured to compare relative levels of light at two locations on the globes at key times of the year.

This activity should take place in a room that can be made to be as dark as possible. Just as the only practical light source in our solar system is the Sun, we want our symbolic Sun to be the only light source for our activity. Black paper can be placed on classroom windows or shades drawn down. A room with some stray light will still work, but might result in higher voltage readings on one or more globes. (Experience shows that this activity works best in a multi-purpose room or on a stage; there is usually ample working space and very little natural light.) Plug the extension cord into the nearest wall outlet and bring the other end to the center of the activity area and plug both power strips into it (tape down the cord).

1. Place a table (large enough for the 4 lamps) in the center of the room that is the same height as the tables or desks on which the globes will be placed.
2. Place 4 small tables or level desks 6 feet away from the center table and 90° from each other (see diagram below). As the students make distance measurements while they set up the model, the distances of these tables/desks may need to be changed in order to place each globe near the center of each table or desk. Mark the position of the table/desk on the floor with masking tape to reference its starting position and ensure consistent data from each successive group.
3. Place lamps, globes, multi-meters, and string on the center table or other table in the room. Each multi-meter should be set to a position four clicks to the left of the top. That setting is labeled “2000m”, and sits in the DCV section.
4. After the students have set up the model, swap the globes (if necessary) so that they are in the correct order (1, 2, 3, 4) according to the diagram below. Students should finalize the creation of the model before adjusting. **Each globe MUST be placed on its respective station table.** Each of the four globes has been pre-tested and designated as to which station will provide the best results. Globe bases have their station numbers printed on them. Mark the positions of the globe bases with masking tape to reference its starting position and ensure consistent data from each successive group.
5. Check that the individual lamps point 90° from each other and that all globes are centered in the light path. Plug the lamps into the power strips.

You have now completed construction of a model of Earth’s orbit around the Sun. The lamps at the center represent the Sun, and the globes represent Earth’s relative position on the first days of summer, autumn, winter, and spring. Earth’s axis points in a nearly constant direction as Earth orbits the Sun, so all globe axes should point in the same direction. Earth’s orbit is nearly a perfect circle, so consistency in distance is important in this model. As part of the activity we *will* move one of the globes to test the effect of changing distance, but for now a consistent distance between the Earth and the Sun is important.

NOTE: The diagram below represents what the set up should look like AFTER the students have created the model based on the guiding questions and class discussion. The set-up instructions below can be used as a guide for what the final set up should consist of, but the actual design of the model should be done by the students based upon the questions at the beginning of the student activity.

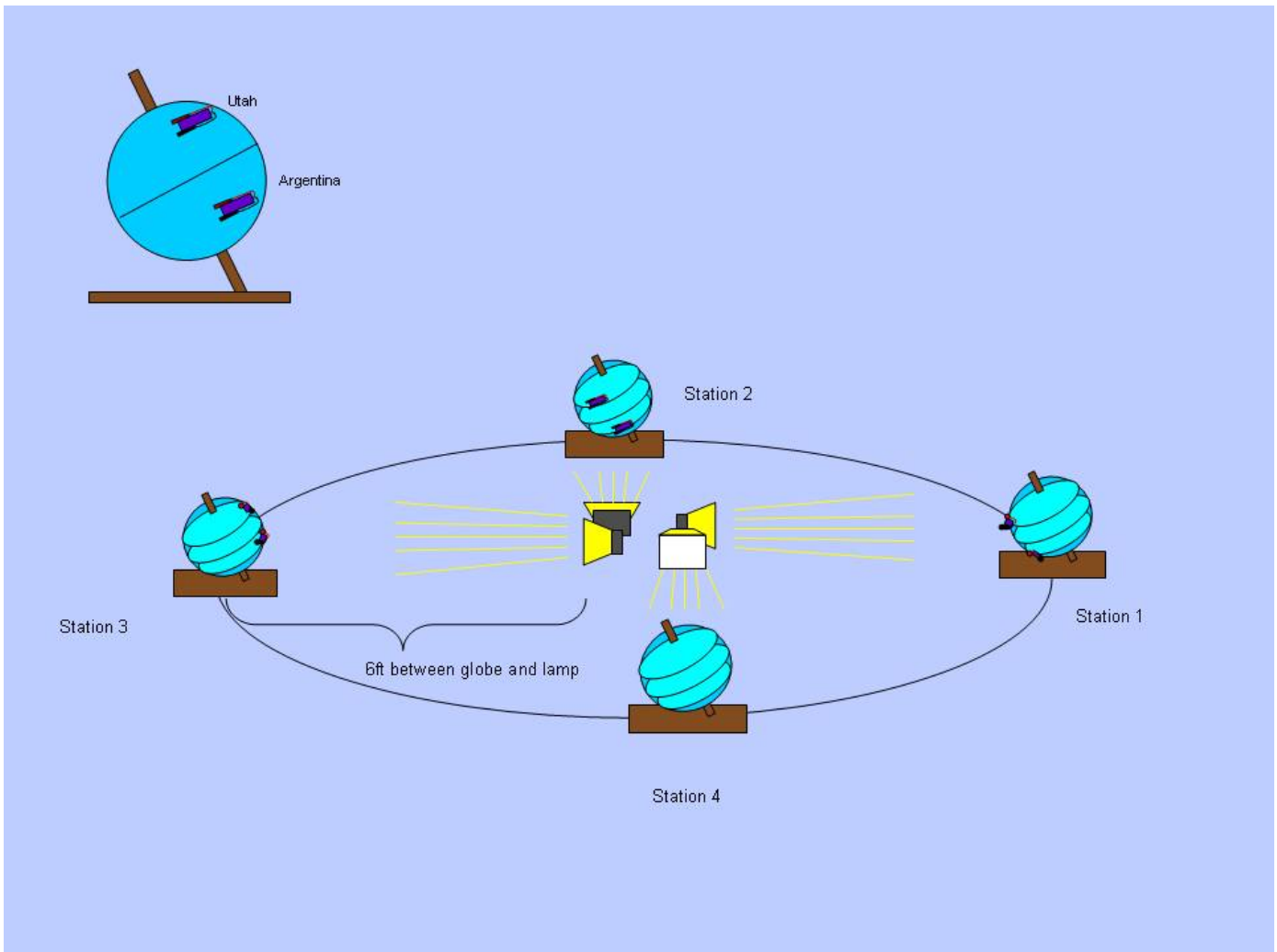

Globe setup diagram (side view)

NOTE: The diagram below represents what the set up should look like AFTER the students have created the model based on the guiding questions and class discussion. The set-up instructions below can be used as a guide for what the final set up should consist of, but the actual design of the model should be done by the students based upon the questions at the beginning of the student activity.

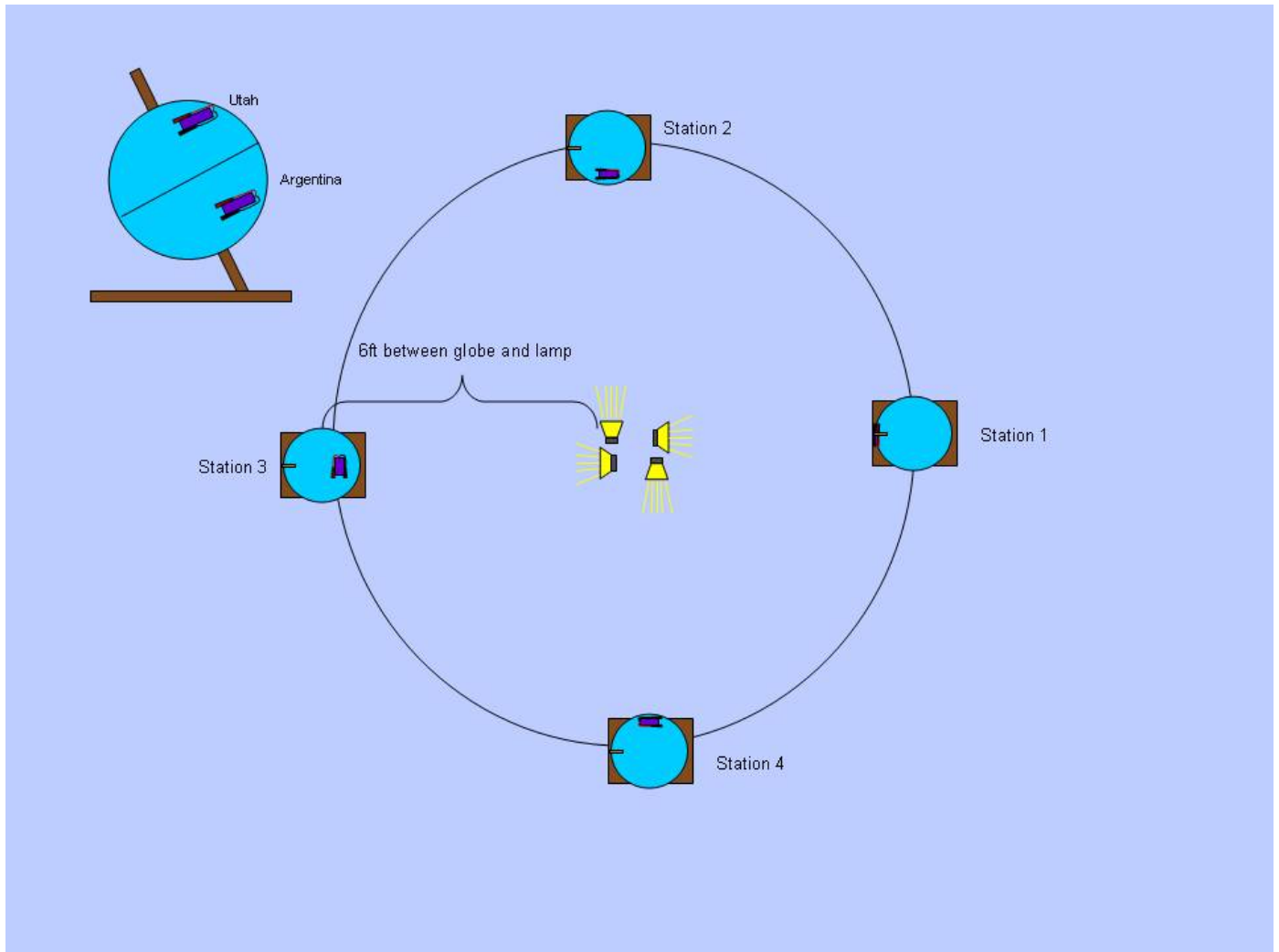

Globe set up diagram (top view)

Helpful Tips:

- If students provide incorrect answers to questions during the discussion, it may be tempting to correct them immediately. A better approach is to ask additional questions that will help students clarify their thinking. Asking them to cite evidence in their arguments may also help.
- Teachers and students are encouraged to use a questioning approach throughout. There are many opportunities for students to make observations that are not necessarily listed below.

Setup checklist:

- Check power and light source.
- Check distance and placement of globes in the light path.
- Check station numbers and verify that they match with their proper globe position.
 - counter clockwise rotation 1-4)
- Check direction of polar axes of globes.
 - Station 1 Utah **leaning** toward the Sun
 - Station 3 **leaning** away from the Sun
 - Stations 2 and 4 neither **leaning** toward or away from the Sun.
- Check stations for pens/pencils.
- Check stations for activity sheets.
- Check stations Multi-Meters. Check for power and proper setting.
 - The Multi-Meters should be set on 2000m DCV. This setting gives the most information to provide as much accuracy as needed for the activity. It is VERY important that the setting on the Multi-Meters does not change, or inconsistent information will be collected from one group to the next.

Procedure:

Student Roles as Scientific Research Groups:

Before beginning the activity separate the class into 4 equal size groups, 4 to 8 students per group depending on class size. (The students can form into their standard work groups or can be randomly organized by the teacher. The teacher should also reserve the right to reorganize groups that will work together more productively). Each student in the scientific group will have a role or responsibility: Probe Specialist (**PS**), Base Holder (**BH**), Globe Rotator (**GR**), Meter Reader (**MR**), Data Recorder (**DR**), Researcher #1 (**R1**), Researcher #2 (**R2**)

- **Probe Specialist (PS):** One student will need to hold the leads from the Multi-Meter in the sockets on the solar energy collectors.
- **Base Watcher/Holder (BH):** One student will need to watch, and if necessary, hold the base of the globe down to keep it from moving.
- **Globe Rotator (GR):** One student will *slowly* rotate the globe on its axis to bring the solar energy collectors being tested more directly into the light.
- **Meter Reader (MR):** One student will read the display on the Multi-Meter to the Data Recorder.
- **Data Recorder (DR):** One student will record the collected data on the activity sheet.
- Additional students in each group could contribute to the study by acting as researchers, **Researcher #1 (R1)** and **Researcher #2 (R2)**, etc. making observations regarding the questions on the activity sheet (i.e. length of the peg shadows, how long is Utah in daylight). Students are encouraged to make other observations that can be shared with the greater scientific community, i.e. “Is the north pole in shadow or light, for how long?”

It is important that these activity procedures are demonstrated by the instructor before allowing the students to proceed with the activity. Students will rotate through each station twice. During the first rotation they will collect data for Utah. During the second rotation they will collect data for Argentina.

To give all students a meaningful experience, it is recommended that the members of each group rotate tasks. This *could* be done by assigning each student in the group a number that would determine that student’s role at each station (see example below). Example Role List

Station #1, Utah	Station #2, Utah	Station #3, Utah	Station #4, Utah
1 – PS	2 – PS	3 – PS	4 – PS
2 – BH	3 – BH	4 – BH	5 – BH
3 – GR	4 – GR	5 – GR	6 – GR
4 – MR	5 – MR	6 – MR	7 – MR
5 – DR	6 – DR	7 – DR	1 – DR
6 – R1	7 – R1	1 – R1	2 – R1
7 – R2	1 – R2	2 – R2	3 – R2
Station #1, Argentina	Station #2, Argentina	Station #3, Argentina	Station #4, Argentina
5 – PS	6 – PS	7 – PS	8 – PS
6 – BH	7 – BH	1 – BH	2 – BH
7 – GR	1 – GR	2 – GR	3 – GR
1 – MR	2 – MR	3 – MR	4 – MR
2 – DR	3 – DR	4 – DR	5 – DR
3 – R1	4 – R1	5 – R1	6 – R1
4 – R2	5 – R2	6 – R2	7 – R2

Safety:

The following precautions should be followed.

1. These lamps put out 500 watts of energy. They are very bright and very hot. Avoid looking directly at the lights. They are not as bright as the real Sun, but can still make it difficult to see in the dark if gazed upon directly. Avoid touching the lamps. Parts of the lamps do get hot enough to cause serious burns.
2. The lamps are plugged into a power strip with an extension cord. There is a risk of tripping on either of these power cords. The power cords can be taped down to present less of a hazard.
3. If room permits, the scientific groups should revolve from station to station around the outside of the activity circle to minimize the risk of touching the hot lamps and burning one's self, tripping on power cords, or bumping the globe stations out of position resulting in a collection of bad data.

Rules:

1. Earth's orbit is nearly a perfect circle. The position of the table is very important for accuracy. Avoid sitting on, leaning on, or pushing on the tables occupied by the globes. Be careful to not move the globe from its position on the table.
2. Standing in the Sun's light and casting a shadow on the Earth is often referred to an Eclipse. We are not learning about Eclipses today, try not to cast shadows or stand in the Sun's light.
3. To ensure everyone's collected data is consistent; do not change the setting on the multi-meter.

Introduction:

- We have observed that the Sun's height in the sky at local noon changes over a year. That pattern repeats every year.
 - When is it highest? (June)
 - When is it lowest? (December)
- Should you ever look directly at the Sun? (No. It can damage your eyes)
- Is there anything we can use to indirectly determine how high the Sun is in the sky? (shadows)
- If there is a vertical stick in the ground, and we observe that the stick's shadow is short, the Sun is . . .? (high in the sky) If the stick's shadow is long the Sun is . . .? (low in the sky)
- We have also observed that the amount of daylight we experience in Utah changes over a year and that pattern also repeats every year.
- Are there other phenomena that repeat every year? (temperature, weather patterns, etc.)
- What do we call these changes? (seasons)
- Why do we have seasons? (usually a student will suggest that Earth is closer to the Sun in summer and farther from the Sun in winter – acknowledge this as a possibility)
- Are there other possible reasons that we have seasons? (accept all without judgment, you may even wish to post a list)
- Scientists often use models to help them understand things better. That's what we're going to do today. We are going to develop a model of the Sun-Earth-Moon system and use it to construct an explanation of the changing Sun height, changing hours of daylight, and the cause of the changing seasons.
- All models are inaccurate in some ways. It is important that we understand what is inaccurate in a particular model so that those inaccuracies will not lead us to a misunderstanding.
- As you work together to build a model of the Earth-Sun system, it is important to think about the ways this model is accurate and the ways the model is inaccurate.
- What objects need to be represented in this model? (Earth & Sun)
- What could we use to represent the Sun? (lamps)

- What do we know about the Sun? (it emits light and heat)
- In what direction does it emit light and heat? (all directions)
- How could the lamps be arranged to best represent the Sun? (place them together in the center of the room facing outward)
- What could we use to represent Earth? (globes)
- What do we know about Earth?
- Does Earth move? (yes)
- What motions does it have? (it spins or rotates on its axis and orbits or revolves around the Sun)
- How long for one rotation? (one day)
- What do we experience as a result of Earth's rotation? (day and night)
- How could we model that with one of the globes? (spin it around)
- How long for one orbit (or revolution)? (one year, about 365 $\frac{1}{4}$ days)
- How could we model that with one of the globes? (carry it around the lamps)
- What are the inaccuracies in this model?
- If the Sun were the size of one of these lamps (a ball 6 inches in diameter), how big would Earth be? Make a circle with your fingers to show me. (It would be the size of the head on a pin.)
- How far away from the Sun would it be at that scale? (about 50 feet)
- Is our model at the correct scale? (No, but it would be difficult to develop one at the correct scale)
- How many Earths are there? (one)
- Why are there four globes? What might they represent in our model? (Earth at four points in its orbit around the Sun)
- How many seasons are there? (four; autumn, winter, spring, summer)
- Where should we place the globes so that each globe would represent Earth at each of the four seasons? (equally spaced around the lamps)
- What do you notice about the globes? (they are at a tilt and have things on them)
- Let's discuss the tilt first. What does the metal rod going through the globe represent? (Earth's axis)
- What is the axis? (an imaginary line around which Earth spins or rotates)
- Is Earth's axis tilted like the axis of the globes? (Yes, by 23.4 degrees)
- Does Earth's axis point in the same direction as it orbits the Sun? (yes)
- Is there any (observational) evidence that it does or does not? (yes)
- Does the axis point toward anything in space? (Earth's northern axis always points toward the North Star, so we know that the axis stays pointed in the same direction as Earth orbits around the Sun. Make sure NOT to pick an object in the room to represent the North Star as everything is far too close.)
- So, in our model, how should we orient the axis tilt of each globe? (they should all point in the same direction)
- Because it would be difficult to develop a model at the correct scale, how far should the globes be placed from the lamps? Is there anything with the materials that could help? (6-foot string)
 - [For consistency, have students measure from the front of the lamp to the center hole in the center of the base of the globe.]
- Does Earth always orbit at the same distance from the Sun? (no)
- How much does the distance change? (1.67%)
- At our scale of 6 feet, what would that be? (about an inch)
- Now that we have the model "Earths" placed around our model "Sun", let's talk about the things on the globes.
- What are these rectangular things on the globes? (solar cells or photodiodes)
 - [If the globe kit you are using has photodiodes instead of solar cells, tell the students that photodiodes work in a similar way as solar cells.]

- What do solar cells do? (convert light into electricity)
- If more light or more intense light shines on a solar cell will it produce more electrical energy? (yes)
- So, if we measure the electrical energy produced by the solar cell or photodiode, will that tell us about the light intensity at that spot on the globe? (yes)
- Is there anything on the globes that might help us find out how high the Sun appears in the sky from Earth? (peg)
- Can we use the peg's shadow length to tell how high the Sun is in the sky? (yes)
- What length of shadow will the peg have if the Sun is high in the sky? (short)
- What length of shadow will the peg have if the Sun is low in the sky? (long)
- Remind students about the scale: If the Sun were the size of one of these lamps (a ball 6 inches in diameter), the Earth would be the size of the head on a pin.) Ask them if the Northern Hemisphere is closer to the sun than the Southern Hemisphere in this model and then ask them if this is true in reality.
 - [Use this question as an opportunity to impress upon students that this model is not to scale. This means that the distance change of a couple inches between the northern and southern hemispheres that accompanies the use of a globe and the six feet distance between the Earth and the Sun becomes negligible at the actual scale of the solar system. This helps to avoid students equating the change in distance caused by the tilt with the seasons so that they can conclude that it is about the changing intensity of light caused by the tilt.
- What are some possible explanations of the reason we experience different seasons every year? (Two common ideas people have are Earth's changing distance from the Sun or the tilt of Earth's axis)
- We can use this model of the Earth-Sun system to test both hypotheses (distance vs. tilt) of what causes the seasons.

Demonstration:

Demonstrate the roles and techniques required to correctly gather data by collecting data for Earth's closest and furthest distance from the sun for later use.

This demonstration should take place with the use of just one globe. Station 1 works well for this demonstration. Leave the other lamps off so students can see. Verify that the multi-meter is turned on and is on the proper setting (DCV 2000m). Turn on the lamp that faces the globe being used for the demonstration; the other three lamps do not need to be used at this time. Turn off the main lights to darken the classroom. Ask for a couple volunteers to help with the demonstration.

Begin the demonstration by positioning the volunteer students and defining their respective roles in detail. (Several roles could be demonstrated by the teacher for both speed and clarity of presentation.)

- Probe Specialist: should place the probe leads from the multi-meter securely in the sockets on the solar energy collectors and remove them when data collection is complete. It is important that the "Probe Specialist" does this carefully so as not to damage the sockets or break them off of the solar collector.
- Base Watcher/Holder: should simply watch the globe base and if necessary, hold it to keep it from moving from its predetermined location. This individual needs to hold the base of the globe securely, but not hinder the movements of the others in the team or cast shadows on the globe.
- Globe Rotator: (to be demonstrated by instructor) should slowly rotate the globe left and right bringing the solar energy collector directly into the light (have the center of the collector facing the light) to achieve the highest number on the multi-meter. The "Globe Rotator" should listen to and follow the direction of the "Meter Reader". After the highest value has been displayed by the meter, the "Meter Reader" should tell the "Globe Rotator" to stop and slowly rotate back the other direction until the highest value has been reestablished by the meter. (Hint: Experience shows that students who rush through this process usually end up with inconsistent

data. When the highest value has been found, the “Globe Rotator” should remove his/her hands momentarily to allow the globe to stand alone and settle for more accurate data. Impress upon the students that their data **MUST BE REPRODUCIBLE!!!** This means that each reading should be attained at least twice) Do not rush through this process or the data will not be accurate.

- Meter Reader: should read the display on the multi-meter and report to the “Globe Rotator” when the greatest value has been displayed by the meter. Working together, the “Meter Reader” and “Globe Rotator” rotate the globe back and forth several times to find the highest consistent value on the meter. When the greatest value has been found, this information will be reported to the “Data Recorder”.
 - The numbers on the multi-meter display will not give an accurate representation of actual seasonal temperatures or values of actual solar radiation. Rather, the numerical values simply provide a reference for comparison, as the intensity of light increases, so does the electrical output from the solar energy collector. Tell the students that a higher number corresponds to more sunlight.
- Data Recorder: records in a clear hand the highest consistent values collected by the “Meter Reader”. Other students in the group will be able to copy the data onto their individual sheets immediately after data collection or a later time. The “Data Recorder” could also collect the results of the student’s inquiries regarding the other learning points on the work sheet.

After the demonstration of scientific roles and while you still have volunteers to help, begin the discussion of the effect that the distance between the Earth and the Sun has on the seasons.

- What is the shape of Earth’s orbit around the Sun? (ellipse or oval.)
- Is this setup an accurate model of the Earth’s orbit around the Sun? (No)
- How is this model different from the real thing? (The Sun is a sphere and casts light in all directions; The Earth shouldn’t be this big compared to the Sun; The Earth should be farther away.)
- Does the shape of Earth’s orbit have any influence or effect on the seasons? (Students will usually have mixed opinions.) This is one of the questions we will answer in this activity.

To collect the data for the near and far extremes of Earth’s elliptical orbit use only the one globe used to demonstrate the student roles. Move the globe about one inch closer to the lamp.

This distance is not exact, but within the scale of our model this change closely resembles Earth’s closest distance to the Sun (the actual orbit is off from a true circle by about 1.6% closer or 1.6% farther away).

Have the Probe Specialist insert the leads for the multi-meter into the solar energy collector **for Utah only** while the teacher holds the multi-meter. The instructor rotates the globe to bring the solar energy collector into the light and reads to the class the changing values on the digital display. Read aloud the 5 or so values on either side of the maximum. Call special attention to the sequential progression of numbers both up and down. When the globe has been oriented so the solar energy collector is receiving as much direct light as possible and the highest number on the multi-meter has been achieved at least twice, record this value in the space provided on the activity sheet. Invite all students to record the maximum number on the data collection sheet. Next, move the globe back about an inch behind its pre-designated position (2 inches from its current position). This represents the farthest point Earth gets from the Sun. The data for Utah should then be collected and recorded in the same manner. (After collecting the data for “Near and Far”, reset the globe to its original position for the remainder of the group activity.) *You are only collecting data now, we will analyze it after the tilt data is collected.*

Data Collection:

Send the four scientific groups to their stations. After the groups are at the stations, have them note which station they are at. At this point it is very important to instruct each group that they are to write the collected information in the correct spaces on the activity sheet (many students need to be reminded that they are not necessarily starting at station

#1). ALL data collection from here through the end of the activity deals with Earth's tilt. If the roles for this station have not been pre-assigned, have the students decide who will perform each task. Each student should record the data on their own worksheet. The scientific groups will collect data in the same manner as the demonstration at each of the four stations; with the exception that they will not be moving the globes to collect data for the near and far distances from the Sun. **For large classes, have the students first collect data only for Utah at each station.** Data for Argentina should be collected during the second pass. This will allow students to experience a greater variety of roles. To keep time to a minimum, the groups will spend no more than 7 or 8 minutes at their first station, gathering data as quickly and accurately as possible. The next 3 rotations should take about ½ the time.

Students should change roles at each station. When most of the groups have collected their data and answered the two questions regarding shadow length and hours of daylight over Utah, announce that the groups should finish with their first station data collection. When all have completed their data collection, announce that it is time to revolve to the next station: 1 to 2, 2 to 3, and so on. **Counterclockwise** as viewed from above the North Pole (see diagram).

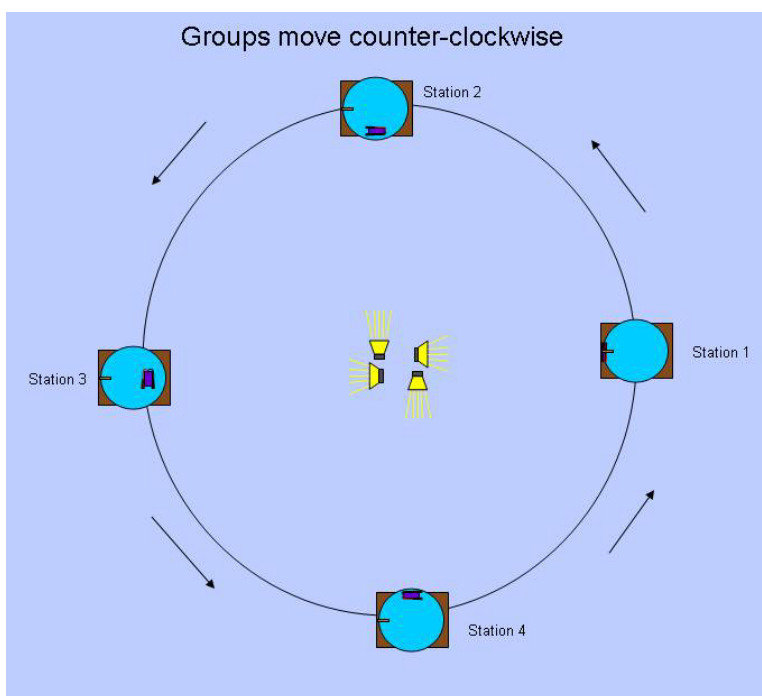

The groups revolve from one station to the next as the instructor dictates, visiting all of the stations twice in a counter clockwise order, completing two full orbits (2 years) of the Earth around the Sun in the proper direction. As the activity progresses, continuously bring students to focus on the reason we experience seasons by drawing the student's attention to the questions on the activity sheet as well as with other relevant thoughts.

- What is the difference between the position of this globe and the globe you were just at?
- "Is the shadow cast by the peg longer or shorter than the last station?"
- At this station, does the Sun ever shine on the north pole?
- What season do you think this station is supposed to represent?
- What is the weather like in China? Australia?

It is very important to periodically check the positions of the globes and the tables against their starting reference markers and make adjustments as necessary, particularly as students are moving from station to station. This could be done by the "Base Holder", or for large groups a student could be assigned as a "Globe Position Checker". The multi-meters should be checked for proper setting as well. This could be done by the "Meter Reader".

Data Analysis:

When the small groups have completed collecting all of the data for Utah, Argentina and answering the two questions for each station, bring the whole class together in front of the white board or projection screen. Keep the groups together so they can collaborate and share their findings with the greater scientific community more efficiently.

Explain again: “The solar energy collectors collect light and turn it into electricity. The multi-meter measures the amount of electricity and gives us a value. A higher value on the meter means there is more concentrated light”.

Ask: “How can we use the data that we collected to help us determine why we have seasons?”

Using the graph on the worksheet transparency for the overhead (or a drawn copy of the graph on the white board for all to see (this could also be done on chart paper for review later), plot the data for Utah collected at the four stations in their respective column, using different colors or symbols to represent each student group on the same graph (each group will likely have differing data that can be used to show variance in data collection and can be analyzed later to find the cause of the anomaly).

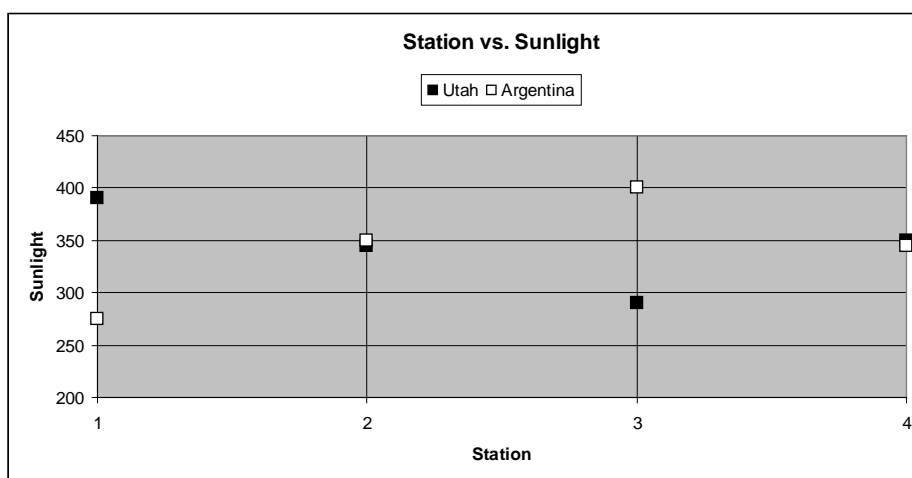

Sample graph showing data for Group 1

Take the data for the near and far distances from the Sun collected for Utah during the demonstration at the beginning of the activity and plot them in a space provided near the graph. Find the change in sunlight compared to the total amount of sunlight between the near and far. (The difference is usually a value of about 4 points or units of energy or about 1% or 2% of the highest value from this station. *Observational note – this percentage is similar to the variance in Earth’s elliptical orbit.*)

Use at least some of these questions to elicit the data needed for analysis:

- Which hypothesis for the reason for the seasons (distance or tilt) shows the greatest change or the greatest percentage difference in the intensity of light in Utah?”
- Does the tilt of the Earth’s axis really have anything to do with our seasons? How? Let’s compare the data you collected.
- Which station had the highest value for Utah?” (Station #1)
 - Reference the work sheet for other notes and observations that were collected
- How long was the shadow of the peg at New York at this station? (Short shadow; Sun is high in the sky)
Students should know that direct sunlight is much more efficient at warming the surface of the Earth because the Sun’s rays are more concentrated in a local area.

- How many hours of daylight were over Utah at station #1? (More than half of a rotation, or more than 12 hours of daylight.)
- Is the tilt of the Earth's axis leaning toward or away from the Sun? (Toward - refer to the station globe if necessary)
- What season do you suppose this might be? (Summer)
- Which station had the lowest value for Utah? (Station #3) Reference the work sheet for other notes and observations that were collected
- How long was the shadow of the peg at New York at this station? (Very long, 3 inches; the Sun is very low in the sky) *Students should know that indirect sunlight or sunlight from very low angles is spread across a larger area and therefore does not warm the Earth's surface as efficiently as direct sunlight.*
- How many hours of daylight were over Utah at station #3? (Less than half of a rotation, or less than 12 hours of daylight.)
- Is the tilt of the Earth's axis leaning toward or away from the Sun? (Away - refer to the station globe if necessary)
- What season do you suppose this might be? (Winter)
- What season do you think Station #2 is supposed to represent?" (Spring or Fall)
- How many hours of daylight were over Utah at station #2? (Half of a rotation; 12 hours of day and 12 hours of night, Equinox)
- What observations can you make to discover which of stations 2 and 4 is spring and which is fall? (Fall, *station 2*, comes after summer and spring, *station 4*, follows winter)
- Does our model help us construct an explanation to explain the phenomena of the yearly repeating patterns of the changing height of the Sun and the changing hours of daylight" (Yes, in the model we can observe that both the changing height of the Sun and the changing hours of daylight that repeat each year result from the tilt of Earth's axis combined with Earth's motion around the Sun.)

Work through the math with the students, pausing to enhance understanding as needed. Remember that you need to treat distance and tilt separately. Distance numbers are typically a difference of 4 out of a total available sunlight of about 400. Tilt numbers (highest amount of sunlight recorded minus least amount of sunlight) are typically around a difference of 125 out of 400 possible. Written as fractions, we compare $4/400$ to $125/400$ since there is usually about 125 points of change from highest summer readings to lowest winter readings. Most students quickly see that $125/400$ is a larger change, but sometimes fraction review is required. (For math extensions, these fractions can be reduced or changed to percent, but experience shows that any further manipulation of the raw numbers initially can lead to confusion).

After working through the Utah example, students should be asked to work in groups to fill in the numbers for Argentina and analyze the data to determine where the seasons fall in Argentina. Have them write several sentences comparing seasons in Utah to Argentina. Example: Seasons are reversed in Utah and Argentina. At station 1 it is summer in Utah and winter in Argentina. At station 3 it is winter in Utah and summer in Argentina.

After completion of this section, you may also want to talk to students about an error analysis, trying to solicit responses about light from windows, light bouncing off of walls, floors, and ceilings affecting the readings as well as the possible variance in multi-meters and different outputs by all 4 solar energy collectors under identical conditions. This is largely why a range in data is seen.

The students can now deduce the real reason for the season using the data they collected and observations they made during the activity. The collected data can also be used for other classroom activities to show comparisons between the northern and southern hemispheres and also similar latitudes around the globe. See the "No Tilt" Globe Activity sheet for an explanation of how to examine an Earth without tilt.



Assessment:

Use the attached worksheet.

Additional Activity

Seasons: Angle of Incidence

Estimated setup time: 15 minutes

Estimated activity time: 15-30 minutes

Description:

This demonstration/activity can be used prior to or after the “Reasons for the Seasons” activities. After some testing, this activity appears to work at least as well as the “linchpin” to solidify understanding when done after the main “Seasons” activity. If used as a post activity, part 2 should be done IMMEDIATELY after Part 1. Connections can be made to light and angle of incidence through this and other inquiry activities in this kit.

In the first part of the activity, students choose multiple angles by rotating a solar cell. *Note: Placing the solar panel too close to the light for prolonged periods can cause it to be damaged. Always keep it 4 feet away or more

Materials Needed:

- Provided in kit:
 - 1 500 W halogen light
 - 1 12 gauge power cord
 - 1 Angle of Incidence Device (PVC tube with attached solar cell mounted to a bookend)
 - 1 multi-meter with probes
 - 1 power strip (optional)
 - 1 Light Area Measurement Grid
 - 1 Board (19" x 14") with hole (This is also the divider in the kit with the lights)
- Additional resources needed:
 - 1 overhead transparency or markers and white board to record data and graph results PowerPoint for teacher
 - 2 Erasable markers of different colors

Teacher Background:

Light is most intense when it strikes a surface at right angles to the surface. When this occurs, the angle of incidence of the incoming light is 0° . When the angle of incidence is greater than 0° , the same amount of light is spread over a larger area. So, there is less light striking each unit of area and light at the surface is less intense. This phenomenon is most pronounced at large angles as small changes angle lead to a large change in area covered—much like the rapid lengthening of shadows just prior to sunset. On Earth, less light striking an area results in less heating of the surface and lower temperatures.

Solar cells convert light energy into electrical energy. Greater light intensity striking a solar cell results in greater output of electrical energy. Since the light output from the Sun or the light used in the activity is essentially constant, the greatest electrical energy is generated when the plane of the solar cell is perpendicular to the light source, a 0° angle of incidence. As the angle of incidence to the light source increases, the energy output of the solar cell decreases because a fixed amount of light is spread over a larger area. As the angle is increased toward 90° in either direction, the electrical energy (voltage) from the solar cell will decrease. This is similar to dumping a glass of water onto a large desk. Since you only have so much water, it must spread out to cover the surface, although it will be at a much shallower depth than when concentrated in the glass.

Setup and Preparation:

Place the 500 Watt halogen light near the front center of the classroom (shinning to one side). Place the Angle of Incidence Device about 6 feet from it in the path of the light. Distance doesn't matter here, as long as it remains constant throughout the procedure.*Note: Make sure the device is not sitting on or near a very reflective surface such as white board, paper on a desk or a window. Make sure the multi-meter is set to 2000 m on the DC scale and that the black probe is in the bottom socket of the meter and the red is in the middle.

Procedure:

Part 1:

Place the 500 Watt halogen light near the front center of the classroom (shinning to one side). Place the Angle of Incidence Device about 6 feet from it in the path of the light. Distance doesn't matter here, as long as it remains constant throughout the procedure. *Note: Make sure the device is not sitting on or near a very reflective surface such as white board, paper on a desk or a window. Make sure the multi-meter is set to 2000 m on the DC scale and that the black probe is in the bottom socket of the meter and the red is in the middle.

Distance MUST remain constant for all readings. Have students predict the results of changing the angle **before** collecting the data.

Keeping the device at a constant distance, select a student to come up and choose the **angle** of the solar cell and take a reading from the multi-meter. Have them graph the result. This can be repeated with as many students as practical but at least 4 readings across the full range should be taken to establish a nice curve on the graph.

Due to issues with reflections off of surfaces, it is best to select degree values for the angle of incidence device between 0° and 90° (going up) or 0° and 90° (going down), **but not both on the same graph**. You can graph them separately and compare the results as an additional activity. Discuss the reason the readings are changing. (Light intensity drops off with a greater angle of incidence.)

Relate this changing angle to the different angles exhibited by the solar cells on the globes at the different seasons.

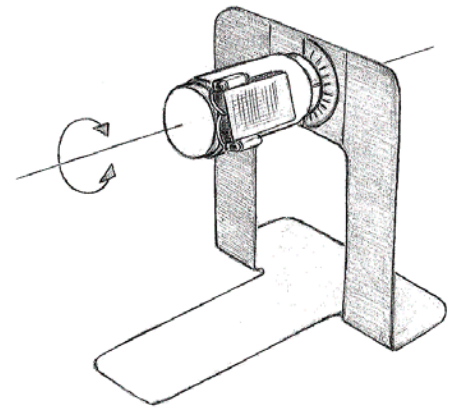

Part 2:

Place the 500 Watt halogen lamp on a desk or table near the middle of the room, facing the front of the room and the "Light Area Measurement Grid". Gather the students around the light so that they can see the "Light Area Measurement Grid". Make sure they do not touch the lamp.

Turn off the lights in the classroom. Hold the board with the hole in front of the lamp. (Be careful not to touch the lamp as it will be hot). The bottom of the board may be rested on the table.

1. With the lamp on, have someone hold the "Light Area Measurement Grid" a few feet in front of the board. The grid should be perpendicular to the board, so that the "angle of incidence" of the light beam is 0 degrees. Have the students observe the intensity of the light on the grid.

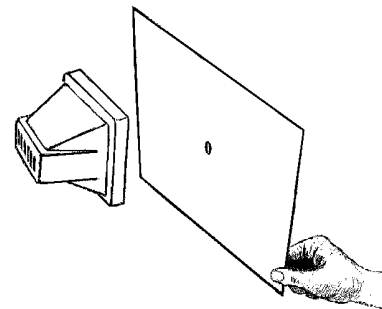

2. Using an erasable marker, trace out the area on the grid that is illuminated by the light passing through the hole in the board.

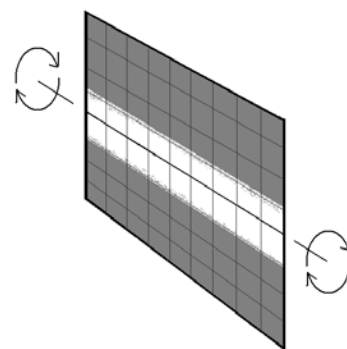

3. Tilt the grid so that the incidence angle of the light beam on the board is more than 45 degrees (until the light is noticeably less intense). Make sure that the actual distance from the light to the grid does not increase.

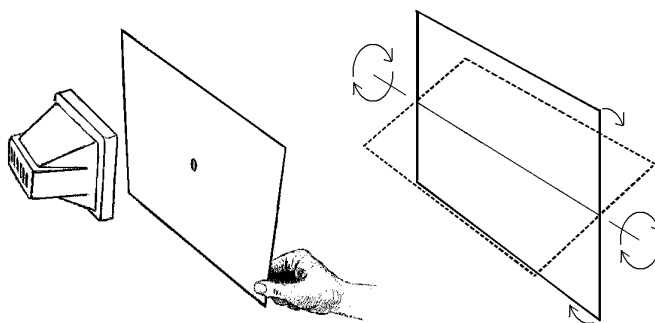

4. Once again, have the students observe the intensity of the light on the grid. Using a separate color, trace out the illuminated area on the grid.

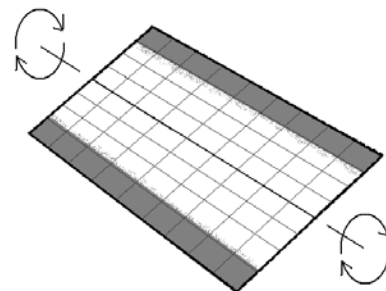

Assessment:

Ask students the following questions:

- What happens to the brightness of the light on the board as the angle of incidence increases? (decreases)
- What happens to the size of the lit area on the board as the angle of incidence increases? (increases)
- Why does the light intensity decrease? (The same amount of light is spread out over a larger area)
- Does the amount of light coming out of the hole in the board change as we tilt the grid? (no)
- How much more area does this same amount of light cover when the grid is tilted to a greater angle? (more, but answers will vary based on angle)
- When the Earth is illuminated by the Sun, do we receive the most energy when the angle of the incident radiation is large or small? (small) At small angles, that means that the Sun is higher in the sky and the Sun's rays strike Earth more directly and provide more efficient heating.



Additional Activity

Seasons: Constellations

Estimated setup time: 15-20 minutes

Estimated activity time: 20 minutes

Description:

This is a quick hands-on activity that allows the students to model the change in constellations seen at various points in Earth's orbit. The use of this model will show how Earth's night side changes direction with respect to the stars as we orbit the Sun. The students will observe how the nighttime star field changes at each of the four seasonal positions. It can be done individually or in groups.

Materials Needed:

- Provided in kit:
 - 4 Earth globes
 - Constellations cards 8 ½ x 11
 - 4 500 watt lamps with stands
 - 1 power strip
 - 1 12 gauge extension cord
 - 1 ruler, measuring tape or 6 ft. string
 - master copy of student worksheet
- Additional resources needed:
 - Darkened multipurpose room or classroom with adequate room to move 4 groups of 4-8 students around 4 stations (area of about 16 ft. in diameter)
 - 1 (or more) electrical outlet(s) on 20 amp breakers
 - 5 desks or small tables (must be level, the same height, and large enough to hold all of the station materials.)
 - pencil/pen (one for each student)
 - copies of student worksheets (one for each student)
 - 1 roll masking tape
 - 1 overhead copy of the Worksheet (for the overhead projector: classroom analysis and comparison) - optional

Teacher Background:

Constellations are groups of stars that form a pattern in the night sky. Constellations can depict people, animals, places or objects. There are 88 official constellations in the night sky. However, not all 88 are visible from Utah. While most constellations used today came from the Greeks, nearly every ancient civilization fashioned their own constellations. Many of your students may already be familiar with some constellations such as: Orion, Hercules, Taurus, Scorpius, Draco, Leo, and Ursa Major. This activity uses the Zodiac constellations, as these are the constellations that the Sun appears to pass “through” or in front of, during a year. This is because those constellations lie in approximately the same plane as Earth’s orbit (and that of the other planets as well).

Because Earth’s axis points in same direction (toward the North Star) throughout its yearly orbit, constellations that surround the North Star can be seen all year long. As Earth rotates, constellations (other than those near the North Star) appear to rise and set, allowing us to see most of sky during the night. However, we cannot see stars in the direction of the Sun because the Sun’s light is too bright. As Earth orbits the Sun, the night side of Earth faces different areas of the sky. This allows us to see different groups of stars over time. Most constellations seen in the spring at a particular time of night are different from constellations seen at that same time in the fall (see diagram below). If we observe the night sky from just after sunset to just before sunrise, we discover that only a handful of constellations are completely hidden by sunlight. For example, if we observe all night, we will see ten or eleven of the Zodiac constellations. Because the stars and constellations that are visible are the same with each orbit, they can be used mark the time of year and herald yearly events. For example, ancient Egyptians knew that when the bright star Sirius first became visible in the morning twilight, it was time for the annual flooding of the Nile, and in Greece the morning rise of the Pleiades signaled the start of the wheat harvest.

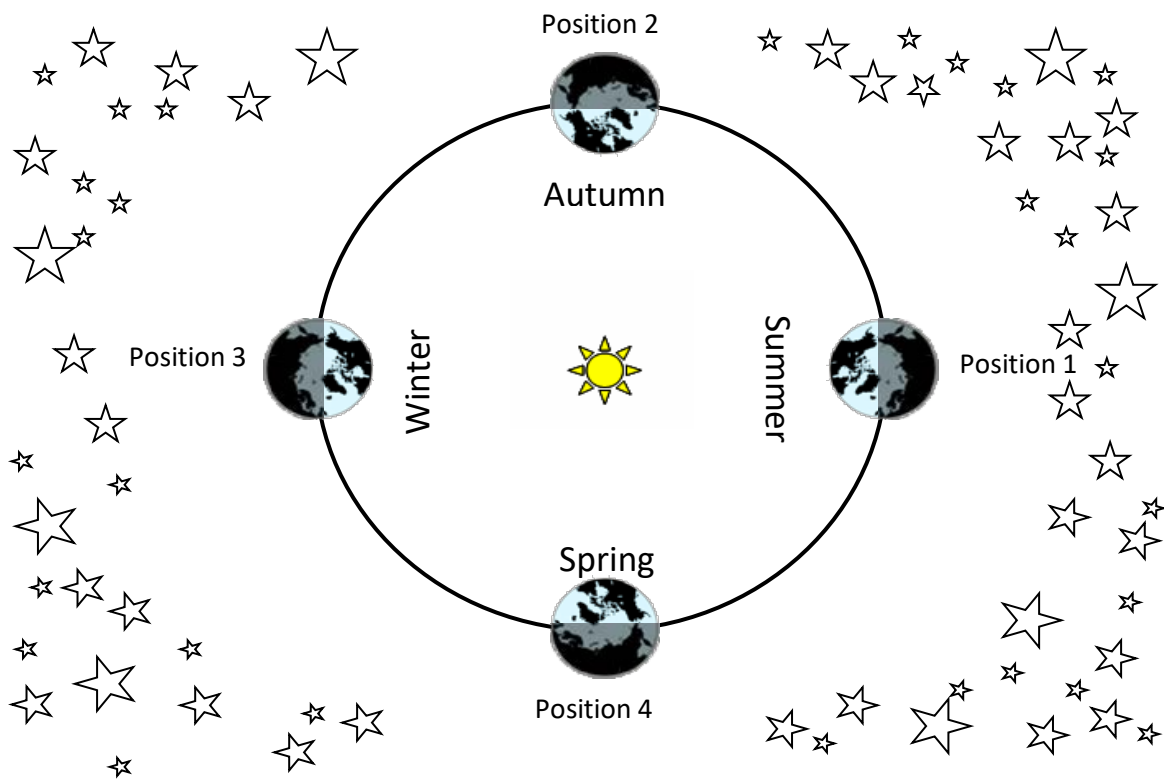

More detailed information: Each day, Earth moves about 1 degree in its orbit. As a result of this slight movement, particular stars will rise about 4 minutes earlier each night. This daily change in rise time results in about a 2 hour (4 minutes x 30 days = 120 minutes) earlier rise after a month. After 3 months (~90 days), Earth has moved about 90°, so constellations will rise a full 6 hours earlier. For example, Taurus rises just after sunset in early December. At the beginning of March, it rises (unseen) about noon and is high in the sky as its stars become visible after sunset.

Common Misconceptions:

- Stars are all the same distance from Earth. (The stars are all different distances from Earth and usually very far apart from each other physically.)
- All of the stars we see are part of our solar system. (There is only one star in our solar system, the Sun; all of the other stars are very far away. The closest star to our sun is Centauri Proxima, 4.2 light years or nearly 25 trillion miles away!)
- Stars appear in the same place every night, all night. Stars slowly move through the sky as Earth turns.
- We see the same constellations all year long.

Setup and Preparation:

This is an extension to the “Seasons” activity. The basic setup is the same, except that the signs of the Zodiac are placed at just below chest level around the room. In this activity, the Sun is represented by the cluster of lamps placed in the center of the room. Four Earth globes should be placed around this structure, each one at approximately six feet from the “Sun” (see diagram below). Make sure to orient each axis in the same direction as in the setup for the main “Seasons” activity. They should all have their axes pointing toward the same side of the classroom and in the order shown in the diagram. The distance between the walls and the globes should be large enough that the students can move between the two freely, and yet still identify the constellations from the far side of the Earth circle. The pattern for the constellations is laid out in the diagram on page 6. Turn on the power for the lights (Sun) just before beginning the activity.

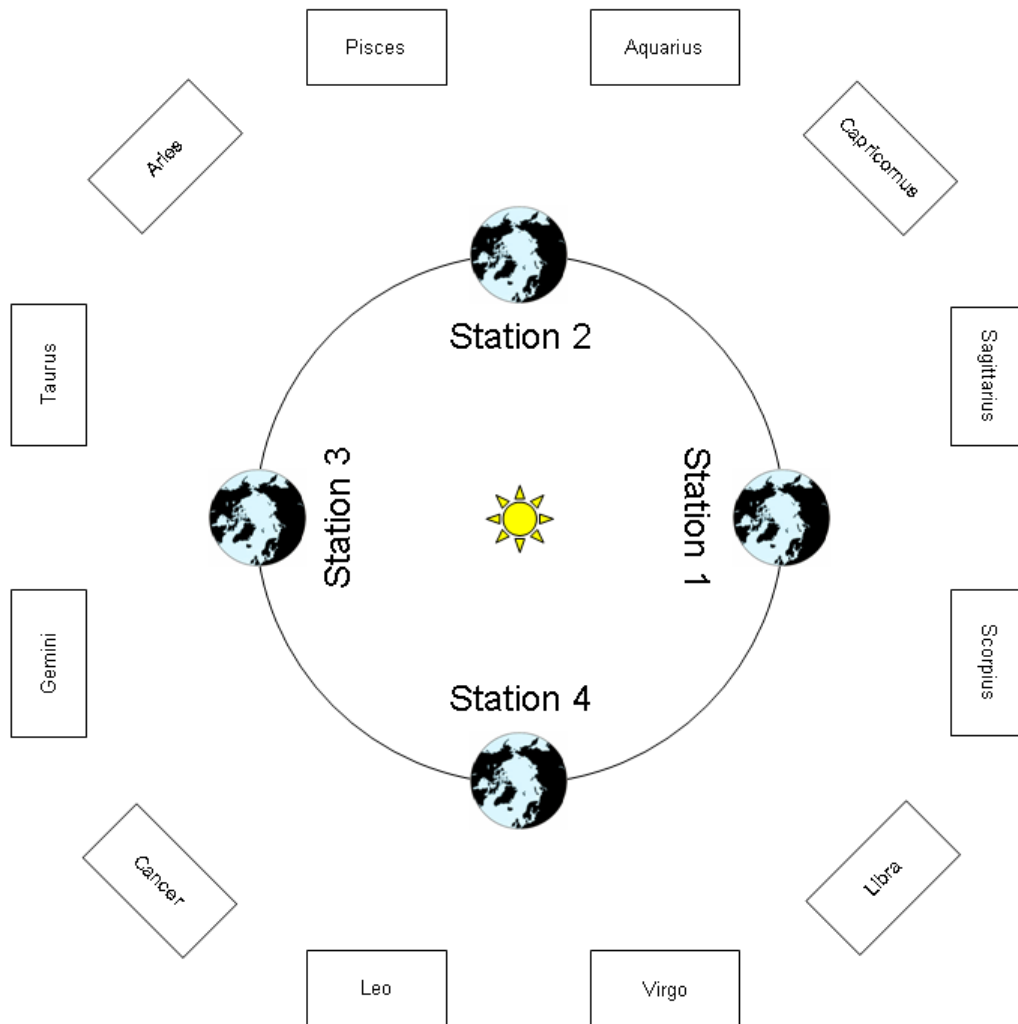

Procedure:

With a worksheet in hand, students will travel to each of the Earth globe stations and fill in the worksheet for that station. At each station, the students should begin by filling in the night side of the Earth. This will help them identify that the night side is facing in different directions throughout the year. Then, they should try to identify which two constellations would be high up in the sky at midnight (facing nearly directly away from the noon position) for their station. These constellations will be the two that are to either side of a line directly opposite that of the sun. What may also help is to have a student stand between their Earth globe and the constellations and hold their hands out straight to the sides, facing away from the sun. This way, they have a full night sky view, from horizon to horizon (their arms). The two constellations that are right in front of them (opposite the sun) will be the ones that are high in the sky at midnight.

After they have visited each of the Earth stations and filled in their worksheet, the students should sit down in their groups and try to answer the questions on the back using the chart they filled in. Be sure to power off the lamps after the students have finished with their observations.

Assessment:

Observation and questioning throughout the activity. Use attached worksheet.



Additional Activity

Seasons: Reason for the Seasons

“Short Version”

Estimated setup time: 20 minutes

Estimated activity time: 30 minutes

Description:

This hands-on activity will challenge students’ common misconceptions by using observation, data collection, analysis and comparison to allow the students to discover the real reason behind the seasons. Students will work together in small scientific groups to research and collect data and convene with the greater scientific community (classroom) to share data and draw conclusions. Students will: measure the amount of direct sunlight at specific locations on the globes, estimate the highest point reached by the Sun and the number of hours of daylight various parts of the Earth receive at different times of the year.

Materials Needed:

- Provided in kit:
 - 4 Earth globes prepared with solar energy collector and pegs
 - 6 digital multi-meters (4 used to measure solar cell output, 2 spares); these units measure the electricity output of the solar cells; they should be set on DCV 2000m
 - 4 500 watt lamps with stands
 - 1 power strip
 - 1 12 gauge extension cord
 - 1 ruler, measuring tape or 6 ft. string
 - master copy of student worksheet
- Additional resources needed:
 - Copy of data sheet for each student or group

Setup and Preparation:

Each globe MUST be placed on its respective station table. (Globes are labeled on top with numbers 1, 2, 3, or 4, as are the bases.) Failure to do so may result in poor data gathering. Using the ruler, measuring tape or 6-foot string, measure the distances between each globe (measure to the center of the globe's base, the vertical hole) and the front face of the light source and adjust where necessary, making sure all globes are the same distance from the light source, and centered in the light path. Mark the positions of the globe bases with masking tape, so as to reference its starting position and ensure consistent data from each successive group.

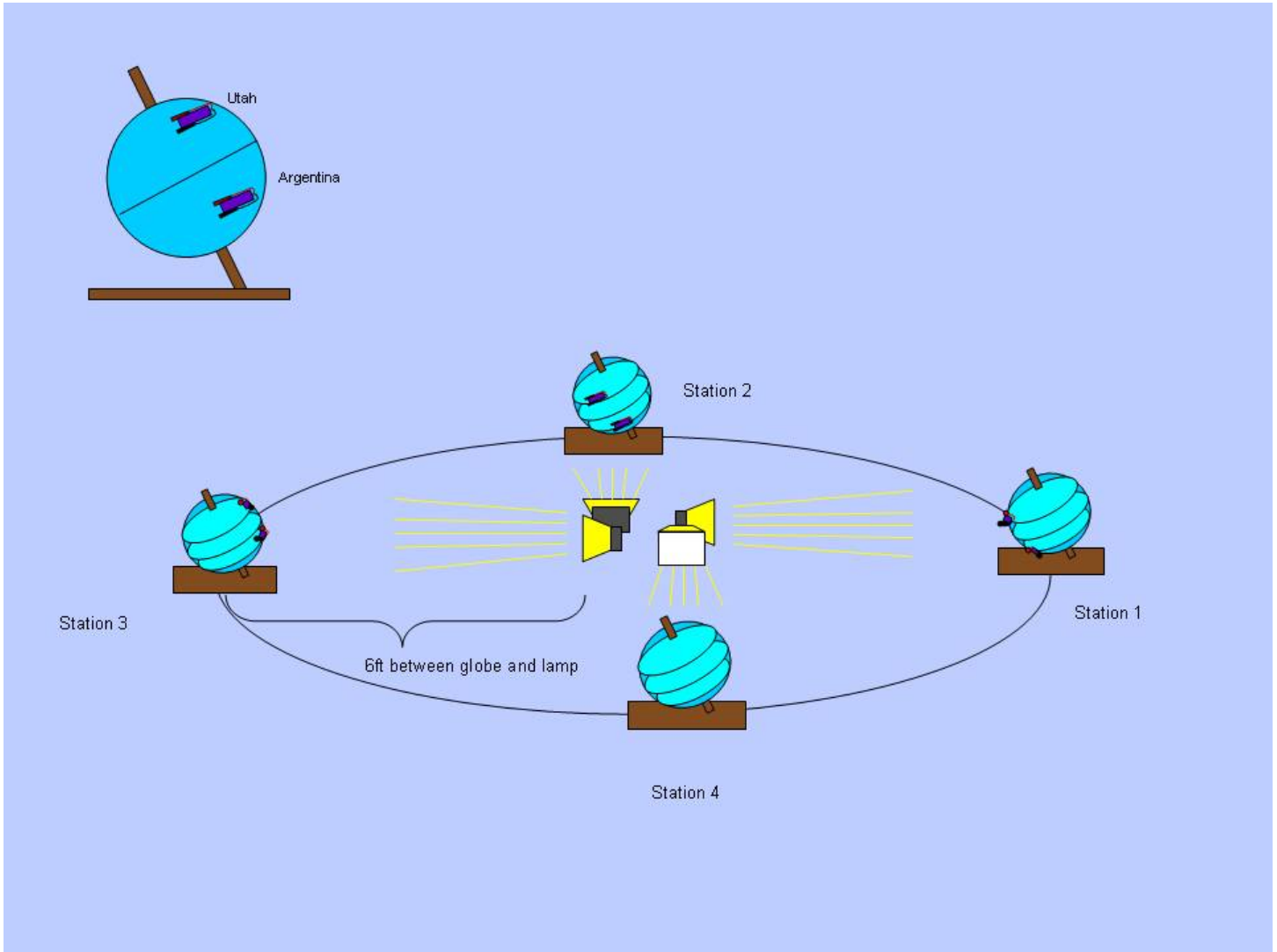

Procedure:

Rules:

- Earth's orbit is nearly a perfect circle. The position of the table is very important for accuracy. Avoid sitting on, leaning on, or pushing on the tables occupied by the globes. Be careful to not move the globe from its position on the table.
- Standing in the Sun's light and casting a shadow on the Earth is often referred to as an Eclipse. We are not learning about Eclipses today, try not to cast shadows or stand in the Sun's light.
- To ensure everyone's collected data is consistent; do not change the setting on the multi-meter.

Introduction:

To give all students a meaningful experience, it is recommended that the members of each group rotate tasks.

- Probe Specialist (PS)
- Base Holder (BH)
- Globe Rotator (GR)
- Meter Reader (MR)
- Data Recorder (DR)
- Researcher #1 (R1)
- Researcher #2 (R2)

Explain that scientists use models to predict what's happening in complex systems.

Introduce activity in an inquiry way, having students explain what the model might represent. Ask a number of the relevant questions at the beginning of the activity.

- How do scientists study complicated subjects? (Models can be used to simplify subjects.)
- What do the lamps represent? (Sun)
- What do the globes represent? (Earth)
- If the Sun were the size of one of these lamps (a ball 6 inches in diameter), how big would Earth be? Make a circle with your fingers to show me. (It would be the size of the head on a pin.)
- How far away from the Sun would it be at that scale? (about 50 feet)
- Is our model at the correct scale? (No, but it would be difficult to use one at the correct scale)

Procedure:

Turn on one light at station 1 to demonstrate the techniques and roles students will assume throughout this activity.

Model skills as you take the “Near and Far” data. Have students record.

Turn on remaining 500 W halogen lights in center of room. Send students to stations to begin data collection.

Circulate between stations to assist students in proper data collection.

The groups revolve from one station to the next as the instructor dictates, visiting all of the stations twice in a counter-clockwise order, completing two full orbits (2 years) of the Earth around the Sun in the proper direction. As the activity progresses, continuously bring students to focus on the reason we experience seasons by drawing the student’s attention to the questions on the activity sheet as well as with other relevant thoughts.

- What is the difference between the position of this globe and the globe you were just at?
- Is the shadow cast by the peg longer or shorter than the last station?
- At this station, does the Sun ever shine on the north pole?
- What season do you think this station is supposed to represent?
- What is the weather like in China?...Australia?

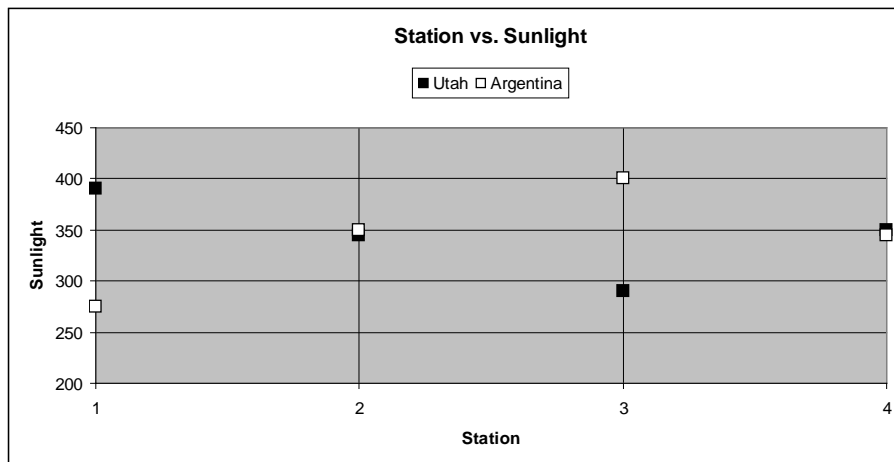

Sample graph showing data for Group 1

It is very important to periodically check the positions of the globes and the tables against their starting reference markers and make adjustments as necessary, particularly as students are moving from station to station. This could be done by the “Base Holder”, or for large groups a student could be assigned as a “Globe Position Checker”. The multi-meters should be checked for proper setting as well. This could be done by the “Meter Reader”.

Take the data for the near and far distances from the Sun collected for Utah during the demonstration at the beginning of the activity and plot them in a space provided near the graph. Find the change in sunlight compared to the total amount of sunlight between the near and far. (The difference is usually a value of about 4 points or units of energy or about 1% or 2% of the highest value from this station. *Observational note – this percentage is similar to the variance in Earth’s elliptical orbit.*)

The students can now deduce the real reason for the season using the data they collected and observations they made during the activity. The collected data can also be used for other classroom activities to show comparisons between the northern and southern hemispheres and also similar latitudes around the globe. See the “No Tilt” Globe Activity sheet for an explanation of how to examine an Earth without tilt.



Additional Activity

Seasons: Tilt, Daylight and Seasons

Estimated setup time: 20 minutes

Estimated activity time: 30 minutes

Description:

Students will use a data table to make a graph for the length of day and average high temperature in Utah. They will then answer questions based on the available data.

Materials Needed:

- Sunrise-Sunset and Temperature Data for Salt Lake City, Utah
- Daylight-Temperature Comparison Graph

Teacher Background:

Earth moves around the Sun in a path that nearly repeats itself about every 365.25 days. Earth's path around the Sun is called its orbit. Contrary to how it appears in most diagrams (including the diagram below), Earth's orbit is almost a perfect circle as is apparent when viewed from directly above.

Earth's axis of rotation is an imaginary line that passes through Earth's north and south poles. Earth rotates around this axis, which causes day and night. Earth's axis of rotation is not straight up and down with respect to its orbit, but it is tilted by about 23.4 degrees with respect to this up and down direction.

Earth's axis of rotation points in the same direction (toward the North Star) as Earth rotates on its axis and moves in its orbit around the sun. Because of this, the length of daylight at a particular location on Earth changes throughout the year (other than at the equator). For example, about June 21 every year, Earth is at a place in its orbit where the northern axis is most leaning toward the Sun. On this day, Utah receives about 15 hours of daylight. With 15 hours of solar heating and only 9 hours of cooling at night, the weather is hot. Six months later, about December 21, Earth is on the other side of the Sun. Here, its northern axis leans away from the Sun and Utah receives only about 9 hours of daylight. Now, with only 9 hours of heating and 15 hours of cooling, the weather is cold. *Note that earth does NOT wobble back and forth each year on its axis as it orbits the sun as many believe.

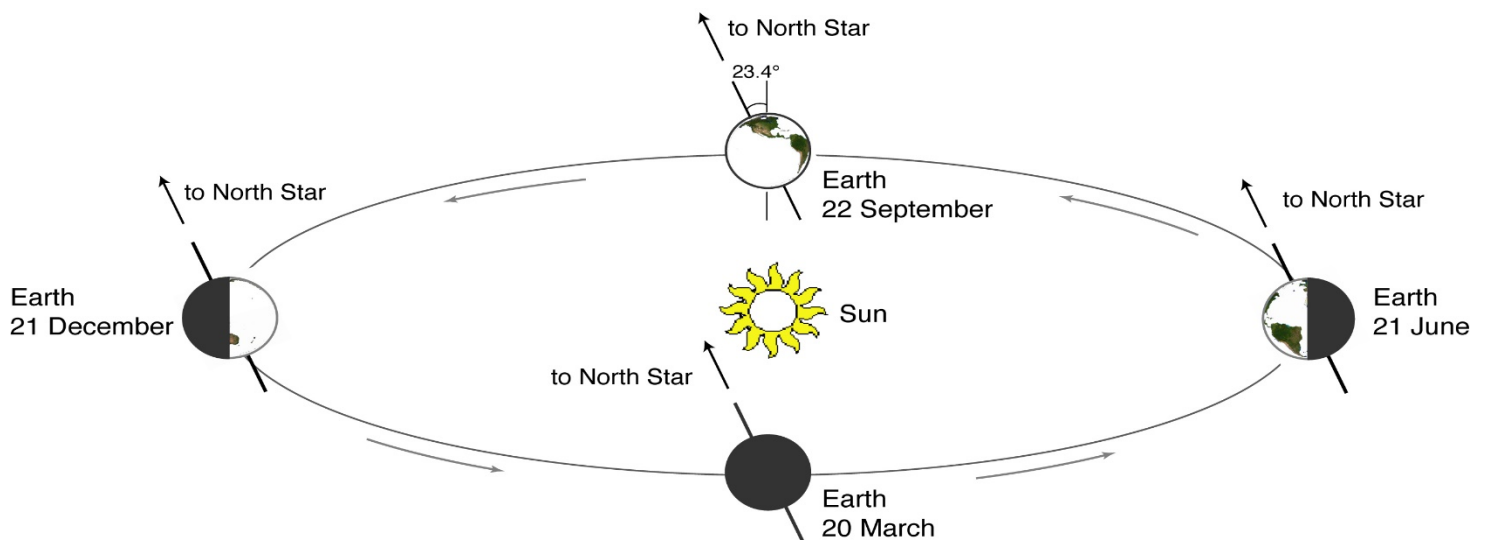

Fig. 1 (Beginning at left, moving counter-clockwise) Earth's position in its orbit on the first day of winter, spring, summer, and fall in the Northern Hemisphere. The seasons are reversed in the Southern Hemisphere. Note: the diagram is not to scale and the orbit is viewed from the side. If the orbit were viewed from above, it would appear to be a circle.

Summer and Winter

Some materials (especially metals) can be heated or cooled quickly. The top layer of Earth's surface (especially if loose dirt or sand) also heats and cools quickly. Other materials (like water) are able to absorb quite a lot of heat without changing their temperature very much, so it takes a long time to heat and cool them. (See "HEATING WATER" below)

Since the sun's rays hit us most directly in Utah in May, June, and July, they do a very good job concentrating the available energy (see "light area measurement grid") on the water and land during this time. This heat energy builds up slowly from day to day. After June 21, the sun is still up almost as high each day (direct light) and daylight is almost as

long. This continues to warm the water and land very efficiently. Because of this, the land and water reach a maximum temperature in late July. After this time, the lower height of the sun and shorter hours of daylight allow cooling to take place. Throughout this process, water takes much longer to warm or cool than does the land.

Similarly, the coldest days are usually around the last week of January or first week of February. A low sun angle (indirect light) and almost as few hours of sunlight as on the winter solstice combine to allow cooling to reach a maximum very near the end of January.

Spring and Fall

Temperatures are cooler in the spring than in the fall for the same reasons as listed above. In the spring, the water and land are still trying to warm up from a cold winter. Fall is warmer than spring because the water and land still retain heat and slowly give up more and more as we approach winter.

Heating Water

A pan filled with water is placed on a stove burner and it is turned on High. While the pan heats up quickly, the water does not. After five minutes, the stove is turned down slightly to Medium-High. Does the water immediately become cooler? No. It is receiving almost as much heat on Medium-High as on High. For a time after the stove is turned down, the water temperature continues to rise.

About 3/4 of Earth's surface is covered by water; in some ways, Earth behaves in a similar way to the pan of water. In the Northern Hemisphere, the maximum heat received from the Sun occurs about June 21. A day later, the amount of heat received from the Sun is only slightly less, so temperatures continue to increase. In fact, the highest average temperatures occur about one month later. Similarly, the lowest average temperatures occur about a month after the date when the Northern Hemisphere receives the least amount of heat from the Sun.

- Why do the days with the greatest amount of daylight not have the highest temperatures?
- Why are the days with the least amount of daylight not the coldest?

Assessment:

Students can complete the "Sun Height Temperature" worksheet, the "Sunrise-Sunset and Temperature Worksheet", and the "Sunlight Temperature Graph".

Phases of the Moon

Estimated setup time: 5 minutes

Estimated activity time: 15-20 minutes

Description:

This is a hands-on activity that will allow students to visually and kinetically explore the phases of the Moon, the arrangement of the Earth, Sun, and Moon at each of the phases, and experience the difference between lunar and solar eclipses. Student's misconceptions about the phases of the Moon will be targeted and addressed in an inquiry setting.

Make sure to review what the moon looks like as it goes through a lunar cycle prior to doing this activity. Once the students know what it looks like from Earth, it will be easier for them to understand the Earth/Moon system in 3D, which will show them that Earth's shadow is NOT the cause of moon phases.

Student Performance Outline:

- Phenomenon – The moon goes through phases that repeat every month and follow a discernible pattern.
- Group Performance
 - Observe the changing phases of the moon throughout the month using the Lunar Phases PowerPoint or astronomy software or (ideally) physical observation of the moon
 - Develop and use a model of the Sun-Earth-Moon system to describe the monthly cyclic patterns of the changing moon phases.
 - Construct an explanation supported by evidence for how the position and revolution of the Earth-Moon system create the phases of the moon
- Individual Performance
 - Complete the Moon Phases Worksheet
- Group discussion

Alignment to Utah 6th Grade SEEd Standards

Strand 6.1: Structure and Motion within the Solar System

The solar system consists of the Sun, planets, and other objects within Sun's gravitational influence. Gravity is the force of attraction between masses. The Sun-Earth-Moon system provides an opportunity to study interactions between objects in the solar system that influence phenomena observed from Earth. Scientists use data from many sources to determine the scale and properties of objects in our solar system.

Standard 6.1.1

Develop and use a model of the Sun-Earth-Moon system to describe the cyclic patterns of lunar phases, eclipses of the Sun and Moon, and seasons. Examples of models could be physical, graphical, or conceptual.

Scientific and Engineering Practices Utilized:

- Developing and using models
- Constructing explanations and designing solutions
- Obtaining, evaluating, and communicating information

Crosscutting Concepts:

- Patterns
- Cause and effect: mechanism and explanation
- Scale, proportion, and quantity

Materials Needed:

- Provided in kit:
 - 36 Golf balls with nails
 - 1 UV lamp with clamp
 - Master worksheet
- Additional resources needed:
 - Darkened multipurpose room or classroom
 - 36 Golf balls with nails
 - 1 UV lamp with clamp
 - Electrical outlet
 - Pencil/pens (enough for all students or groups)

Teacher Background:

The phases of the Moon are caused by the Sun's light reflecting off the Moon's surface in combination with the Moon's orbit around Earth. The Sun always illuminates half of the Moon. As the Moon travels around Earth our perspective changes and so does the amount of the lighted half of the Moon that is visible to us.

The Moon orbits around Earth from West to East. This may confuse some students because, as seen from Earth, the Moon appears to rise in the East, move westward across the sky, then set in the West. However, this apparent motion of the Moon results from Earth's rotation (spinning), not the revolution (orbit) of the Moon. The Moon orbits Earth from west to east slowly. It takes 29.5 days or about one month (or "moonth") to orbit Earth and return to the same phase. This slow trek eastward can be noticed by observing that the Moon rises on average about 45 minutes later each day.

When the Moon is at its new phase, the side opposite us is lit by the Sun and it is impossible to see the unlit side of the Moon. Two days after new moon, the Moon has moved enough for a small portion of the lit side to be seen, a crescent. As the Moon continues to orbit Earth more of its sunlit surface can be seen and the Moon is said to be waxing (growing). In about seven days the Moon goes from new to waxing crescent to its first quarter phase, where we see a quarter of the Moon's surface (1/2 the illuminated surface) illuminated by the Sun. As the Moon continues to travel around Earth, it proceeds from a waxing gibbous to a full moon. At the full moon phase, the Moon's surface that we see is fully illuminated and the bright moonlight can even cast shadows on earthly objects. After the full moon, less and less of the Moon's lighted surface is seen and the Moon is said to be waning. Over the next 14-15 days the Moon will slowly change to a waning gibbous followed by third quarter, waning crescent, then finally back to a new moon.

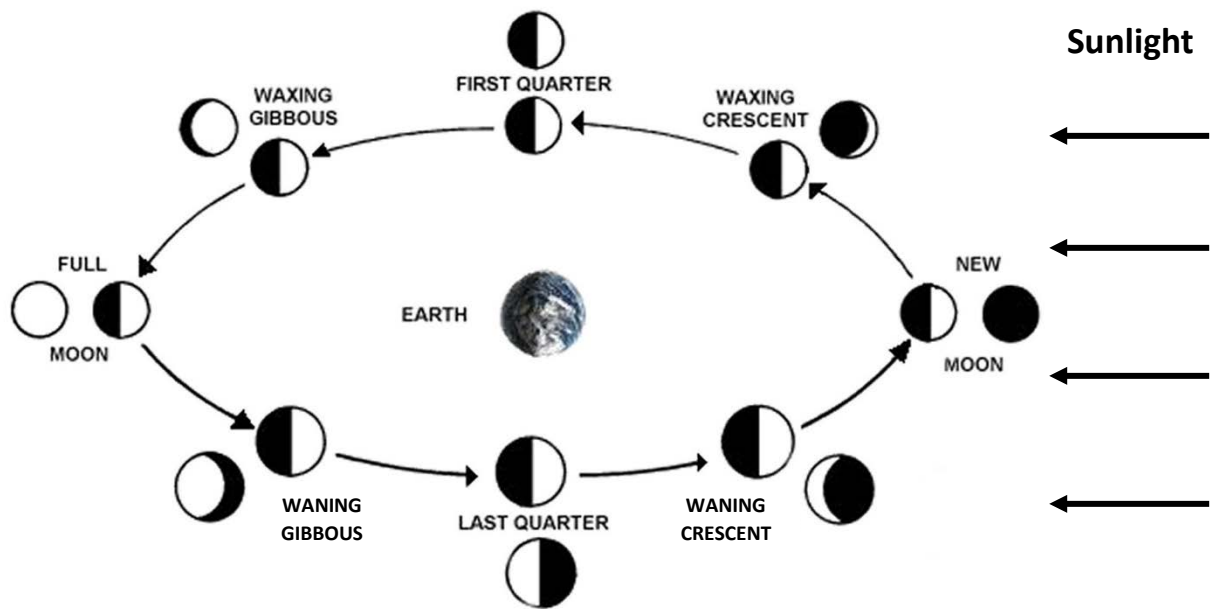

Outer circle depicts lunar phases as viewed from Earth

One way to help students identify waxing phases from waning phases is to use their hands. If they can line up the lit side of the Moon with a *backward* "C" made with their RIGHT hand (below right), it is a WAXING Moon. If they can line up the lit side of the Moon with a "C" made with their LEFT hand, it is a WANING Moon (below left).

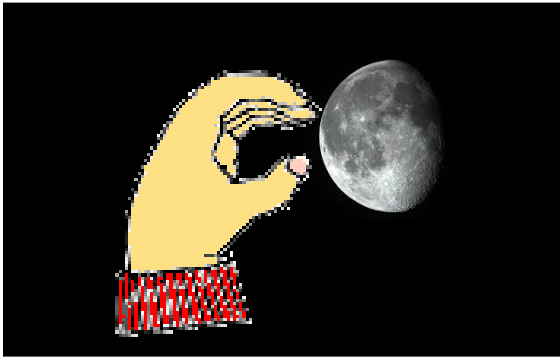

Left Hand - Waning

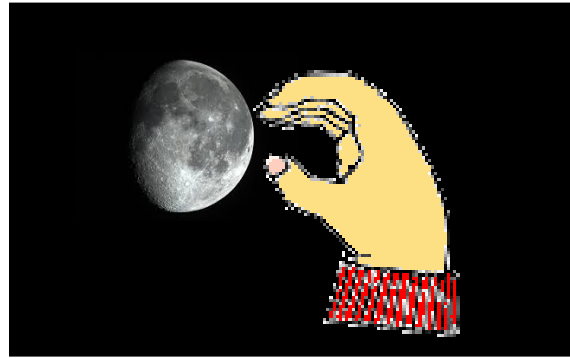

Right Hand - Waxing

As the Moon revolves around Earth, the angle between the Sun and the Moon, as seen from Earth, changes. At the new moon phase, the Moon and the Sun lie in the same direction. At full moon, the Sun is seen opposite to the Moon in the sky. For this reason, the full moon rises at sunset (see below). This can be understood by visualizing the linear arrangement of the Sun, Earth, and the Moon.

Common Misconceptions:

Be aware that there are many misconceptions that students and adults have about the Moon and its phases. Some of these are:

1. The Moon shines because it is generating its own light.
2. The Moon has phases because clouds cover its surface.
3. The Moon has phases because Earth's shadow is being cast on it.
4. The Moon is visible every night and not visible during the day.
5. The Sun and Moon are the same size.



Setup and Preparation:

This activity should be done in a room made as dark as possible. It is essential to have a dark environment or the phases on the golf balls will be difficult to observe. Any windows or outside light sources can be covered with black paper, plastic; the darker the better. Clamp the UV light to something stable such as a wall at the front of the room and point the light toward the students. It is best to have the lamp at eye level or a little above to reduce problems with shadows. Distribute the golf balls (on a nail), giving one to each student. Golf balls will fluoresce (glow) with exposure to ultra violet (UV) light. The UV light will cause some of the student's clothing to fluoresce too! Later, the assessment worksheets and additional activities may be handed out.

If the UV light is the Sun, the student's head is the Earth, and the golf ball is the Moon. Students can move the golf ball around their head and see different phases on the golf ball. Students can then make observations and learn to correctly model the pattern of the phases. Students can also make a solar and lunar eclipse happen in this setting and learn the difference between the two.

Helpful Tips:

- Placing the lamp a little above head level and placing taller students in the back will help diminish shadows cast on other students.
- Have students be an extended arm's width from the nearest student so they don't hit each other.
- Always keep at least six feet of clear space in front of the lamp so large shadows are not cast.

Procedure:

Safety:

The following precautions should be followed.

- The black light lamps put out 27 watts of energy. It is hard to see with a black light so watch your step. Avoid touching the lamp as parts may get very hot.
- Do not look directly into the black light for a long period of time.
- Handle golf ball and nails with care. Don't allow horsing around by the students.
- If needed, tape down the power cord and make sure any other obstructions are out of the way so students don't trip over or run into them.

Rules:

- This lesson will require a lot of turning and arm motion. Please do not stand too close to the black light to avoid knocking it over or causing shadows.
- The room will get very dark but the black light will be on. Please sit still and wait for your eyes to adjust and for further instructions.
- Make sure there is enough room between you and the next person.

Introduction:

Have students recall the observations of lunar phases that they have completed or show the PowerPoint of the lunar phases so that students have a phenomenon to work from.

Scientists often use models and observation to help them understand things better. This is what we will be doing today to try and understand the phases of the moon.

- How many moons does Earth have? (One)
- Why does the Moon shine? (Reflected sunlight)
 - Listen for student's theories. Write a list of them on the board.
- What can we use to represent the moon in our model? (The golf balls)
- What can we use to represent the sun in our model? (The black light)
- What can we use to represent the Earth? (Our heads)
 - Say, "Our heads will represent the Earth."
- If the Moon really was the size of the golf ball, how big would Earth be? Make a circle with your hands/fingers to show me. (6-inch diameter ball)
- Are the Sun and the Moon the same size? (No, the Sun is 400 times bigger than the Moon but it is also 400 times farther away from the earth making it look the same size.)
- Is our model to the correct distance scale? (No. It would be very difficult to use at the correct scale.)
- Why does the Moon change shape? (We are seeing different amounts of the lit-up side)
 - Again list and listen; leave this list on the board for comparison later. Many will say that phases are the shadow of Earth falling on the Moon.
- Does the Moon rise and set at the same times every day? (No)
- Can you see the Moon every night? (No)
- Can the Moon be seen in the daytime? (Yes, about as often as at night)
- Do all people on Earth see the same phase of the Moon on the same day? (Yes)

Acting out the Model:

1. Have students stand in a semi-circle around the black light. Remind them that in the model they just created their head is Earth and their nose is their home town and that the black light represents the Sun.
2. Tell them to take 1 to 2 minutes to explore moon phases while being careful not to get in the way of other classmates. Turn on the black light and then turn off the overhead lights.
 - a. Note that the black light will make the golf balls and some of the student's teeth and clothing fluoresce. Students may take a moment to have their eyes adjust and get their wiggles out. Allow them 1-2 minutes for free exploration (most of which will be spent looking at their clothes). Teachers will assess through direct observation throughout the activity.
3. After most have experimented with many different Moon positions, ask everyone to try and make their moon go through the phases of the moon that they have observed. How can they use their set up to model what they see in the sky?
4. Now, ask which way they have to move the Moon so that it revolves (orbits) correctly, based on their previous observations of the Moon (e.g. a waxing moon is lit on the right side). Encourage them to confer with their neighbors. Try to elicit the correct responses without giving away the answer (counterclockwise as viewed from the North Pole).
5. Have students demonstrate a full moon. For those students with shadows from their heads covering the moon, encourage them to hold their moons higher. Ask them to try moving their moons up and down and observe what happens. Is it still a full moon? (Lunar eclipses don't occur when it is too high or too low relative to the student's faces).
6. Ask students to demonstrate the position for new moon. If they move their moon up and down vertically is it still a new moon? Ask if they can see the new moon reflecting any light. Can they make a solar eclipse? Hint for the students: Try closing one eye and then positioning the golf ball to make an eclipse and then close that eye and open the other. What happens? (They no longer see an eclipse. This helps students to understand why solar eclipses aren't seen everywhere on the Earth). They could also try this with a lunar eclipse set up and see that they can see the eclipse with either eye showing how lunar eclipses are seen everywhere.
7. Next, have students demonstrate both first and last quarter phases, then waxing and waning crescents.
8. Putting it all together, have students start with new moon and demonstrate the whole lunar cycle ~29.5 days.
9. If time permits, have students explore the craters on the moon by looking to see if all craters are illuminated the same way or if there are shadows in some of the craters. Are the craters easier to see at certain phases than others?

Take questions and try to get members within the group of students to answer. Provide guidance as necessary.

Assessment:

- The worksheet provided will provide one of the necessary bridges that will force students to translate this kinesthetic modeling experience into a formal written context. Copy enough Moon Phases worksheets for each student or group.
- Use the golf balls and the moon outside during the day (make sure the moon is up) to show that the phases occur during the day and that Moon rises at different times each day. Safety: Remind students to never look at the sun!!
- Have students hold their golf ball up high above their heads in the direction of the moon. The ball should have a shadow similar to that of the Moon in the sky. This activity also helps students to understand lunar phases are not caused by the Earth's shadow.



Phase Cards:

To do the Phase Card activity, have students (individually or in groups) cut and label the pictures of the moon phases (groups should be no larger than three students).

Game time! Have the students turn over their moon phase cards so they can't see the pictures. On the count of three have them flip them over and quickly put them in the right order starting with the New Moon. This should take no longer than a minute. Discuss the right order as a group.

Discuss why the moon has phases and make a new list to compare to their initial list. Are there any changes? Why? Summarize the phases and eclipses again.

Exploring Eclipses

Estimated setup time: 15 minutes

Estimated activity time: 15-30 minutes

Description:

This is a hands-on activity that will allow students to visually and kinetically explore the phases of the Moon, the arrangement of the Earth, Sun, and Moon at each of the phases, and experience the difference between lunar and solar eclipses. Student's misconceptions about the phases of the Moon will be targeted and addressed in an inquiry setting.

Make sure to review what the moon looks like as it goes through a lunar cycle prior to doing this activity. Once the students know what it looks like from Earth, it will be easier for them to understand the Earth/Moon system in 3D, which will show them that Earth's shadow is NOT the cause of moon phases.

Student Performance Outline:

- Phenomenon – Solar and lunar eclipses do not occur randomly, but instead follow a specific pattern.
- Individual Performance
 - Analyze the eclipse data sheet and look for patterns in the data
- Group Discussion
- Group Performance
 - Develop and use a model of the Sun-Earth-Moon system to describe the two types of eclipses
 - Construct an explanation supported by evidence for how the position and revolution of the Earth-Moon system create the phases of the moon
- Individual Performance
 - Use observations and experiences from the Moon Phase activity to develop an explanation for why lunar eclipses do not happen every month.
 - OPTIONAL: Analyze lunar eclipse diagrams as an aid to determine why lunar eclipses don't occur every month
- Group discussion

Alignment to Utah 6th Grade SEEd Standards

Strand 6.1: Structure and Motion within the Solar System

The solar system consists of the Sun, planets, and other objects within Sun's gravitational influence. Gravity is the force of attraction between masses. The Sun-Earth-Moon system provides an opportunity to study interactions between objects in the solar system that influence phenomena observed from Earth. Scientists use data from many sources to determine the scale and properties of objects in our solar system.

Standard 6.1.1

Develop and use a model of the Sun-Earth-Moon system to describe the cyclic patterns of lunar phases, eclipses of the Sun and Moon, and seasons. Examples of models could be physical, graphical, or conceptual.

Scientific and Engineering Practices Utilized:

- Developing and using models
- Constructing explanations and designing solutions
- Obtaining, evaluating, and communicating information

Crosscutting Concepts:

- Patterns
- Cause and effect: mechanism and explanation
- Scale, proportion, and quantity

Teacher Background:

Eclipses occur when an object in space casts a shadow upon another object. On Earth, two types of eclipses can occur, solar and lunar. A solar eclipse is when the Moon passes in front of the Sun and casts a shadow on a small portion of the Earth. A solar eclipse always occurs during the new Moon phase. The disk of the Moon is just the right size to cover the Sun. However, the Moon is not the same size as the Sun; it looks like the same size because the Moon is closer to us. The Sun is 400 times larger than the Moon, but the Moon is 400 times closer to us. In the small area of the Earth shadowed by the Moon during a total solar eclipse, day seems to turn to early night as even stars begin to become visible.



Solar Eclipse

A lunar eclipse occurs when the Moon passes through Earth's shadow in space. The Moon is in its full moon phase during the eclipse. When passing through the Earth's shadow, the Moon is usually at least slightly visible. This is because light from the Sun is refracted through our atmosphere. Most of the light is scattered (the reason we have a blue sky) but long red wavelengths of light make it through the atmosphere. During totality, the only light getting to the moon is light that has passed through Earth's atmosphere. This causes the Moon to become a reddish color during a lunar eclipse.



Lunar Eclipse

Eclipses do not occur every month because the Moon's orbit is tilted by about 5° compared to Earth's. This causes the Moon to pass a little above or a little below the Earth's shadow every month. Only about twice each year do the Sun, Moon, and Earth line up just right for an eclipse to occur.

Common Misconceptions:

It is not dangerous to be outside during a **lunar** eclipse. However, a solar eclipse should only be viewed with appropriate solar filters or other safe methods such as image projection.

Setup and Preparation:

For details, refer to setup for "The Reasons for the Seasons" activity in this binder. In general, place the 4 halogen lamps in the center of a 12-foot diameter circle shining out at 90 degree angles to each other. Globes should be positioned on the outer edge of the circle at the N, S, E, and W directions. Each lamp should face 1 globe.

Helpful Tips:

During your classroom discussion about eclipses you can mention the recent total solar eclipse that occurred in the US on August 21, 2017 (which students may have seen) or another similar recent event.

*It is important that students are thinking about moon phases so if it has been a while since they learned about them, a short review of lunar phases before the activity would be extremely helpful. *

Materials Needed:

- Provided in kit:
 - 4 Earth globes prepared with solar energy collectors and pegs
 - 4 500 watt lamps with stands
 - 2 power strips
 - 1 12-gauge extension cord
 - 36 Golf balls with nails
- Additional resources needed:
 - Activity Sheets for students
 - PowerPoint for teacher

Procedure:

Data Analysis:

Ask students if they have ever seen an eclipse. Solar or lunar? What is the difference? Hand out the Eclipse and Moon Phases Dates 2006-2016 data sheet and project the same data using the PowerPoint. To avoid confusion, make sure to tell students that only moon phase dates that are near the dates of eclipses are listed. Ask students to look for patterns in the data either individually or in small groups. The five patterns that they should identify are

1. Solar eclipses occur during a new moon
2. Lunar eclipses occur during a full moon
3. Eclipses don't occur every month
4. Solar eclipses and lunar eclipses occur roughly 15 days apart
5. The pairs of eclipses occur roughly every six months.

As a class discuss the student's observations and use the data to help them reach any of the conclusions they may have missed. Then divide them up into 4 groups (one group to each station) and ask them the following two questions.

1. What are the relative positions of Earth, Moon and Sun at the time of a solar eclipse? (Sun, Moon, Earth)
2. What are the relative positions of Earth, Moon and Sun at the time of a lunar eclipse? (Sun, Earth, Moon)

Have them make a diagram of each type of eclipse on a sheet of paper.

Building the Model:

Assuming the students are familiar with the Reason for the Seasons activity, refresh their memories by asking what represents the sun (lamps) and what represents the Earth (globes). Ask them what can be used to represent the moon (golf balls-used in moon phases activity). Distribute 1 golf ball (with nail) to each group. Turn on the (4) 500 W halogen lights in the center of the room to represent the Sun. Turn off the main room lights. Globes should be positioned 6 feet from the lamps as in the setup for "Reasons for the Seasons" activity. Make sure to tape the power cord down to the floor for safety.

Tell students to use their group drawings to model the conditions for a **solar eclipse**. If their model is not correct guide them by reminding them to go back to the data sheet and figure out what phase the moon is in during a solar eclipse (new) and then to use their knowledge of lunar phases to create the right set up.

Next, instruct students to use their group drawings to model the conditions for a **lunar eclipse**. If their model is not correct guide them by reminding them to go back to the data sheet and figure out what phase the moon is in during a lunar eclipse (full) and then to use their knowledge of lunar phases to create the right set up.

*Students will NOT rotate to another station, as the same conditions are close to the same at all stations (at least for 6th grade students).

During the Moon Phases activity students should have experimented with moving the "moon" up and down in the full moon position. From this they should be able to start thinking about why we don't see lunar eclipses every month (The moon orbits at a tilt). Ask students to try and use that knowledge and their new knowledge of eclipses to develop a hypothesis to explain why lunar eclipses don't happen every month.

Optional:

Turn the room lights back on, turn the "Sun" off, and go to the closer look at lunar eclipses part of the PowerPoint. Looking at the slide showing the Total Lunar Eclipse of 2003 and reading the information at the top of the student sheet help students to be clear on the fact that the dotted line in all three diagrams, labelled

“Ecliptic” is a projection of Earth’s orbit around the Sun into space and that the arrows in all three diagrams show the direction of the Moon’s motion and also show the Moon’s orbit around Earth. The umbra is the part of Earth’s shadow where all the Sun’s light is blocked by Earth. The penumbra is the part of Earth’s shadow where only part of the Sun’s light is blocked by Earth.

Ask them to individually look at the three different diagrams showing the three lunar eclipses and to look for patterns. Then come back together as a class and ask the three questions on the PowerPoint.

1. Is the Moon’s orbit around Earth in the same plane as Earth’s orbit around the Sun? (No, it is tilted by about 5 degrees)
2. When there is no lunar eclipse at the time of a full moon, where is the Moon in relation to Earth’s shadow? (Outside of the penumbra)
3. Can we model the motion of the Moon to account for the phenomena using the set up already created?

Tell students to go back to the station they were at and see if they can make a model of their hypothesis so that lunar eclipses (and solar eclipses) don’t occur and give them 2-5 minutes to explore. They may have trouble visualizing what the orbit would look like since they are holding only one golf ball. Students may try to hold the golf ball above or below their head for the entire orbit. Remind them that orbits must pass by the center of the Earth so if it is above their head on one side then it must be below their head on the other side.

Students may struggle to visualize how to model this because it can be hard to visualize the orbit path of the moon. To help students understand why lunar eclipses don’t happen every month we recommend using a hula hoop to show the tilted orbit. Give students a hula hoop and see if they can use that to model the orbit of the moon.

Guiding questions after students have started to try tilting the hula hoop:

- What do we know about the Earth’s tilt as it moves around the sun? (It does not change)
- Does the moon’s orbit of the Earth change as it moves around the sun? (No)
- Have students try moving their tilted hula hoop from one globe to another. Now is there an eclipse? (Depends on what their starting position was)
- Once students have reached the conclusion that the moon’s orbit is tilted in comparison to Earth’s, ask them how much do they think it is tilted by? (Answers will likely be in the 30°-35° angle range because that is what is necessary to make a discernible difference in this model)
- Tell students that it is actually only tilted 5°. Ask students why holding it at a 5° angle wouldn’t work in this model. (Inaccurate scale)
- Next, have student’s move the tilted hula hoop from one globe to the next and have them point out where eclipses occur and where they don’t. This serves to reinforce that at some places in the Earth’s orbit, the moon’s orbit aligns to make eclipses occur and how at others it is above or below so that eclipses do not occur.

Come back together as a class with the lights on and has a discussion of the observations and conclusions the students reached.

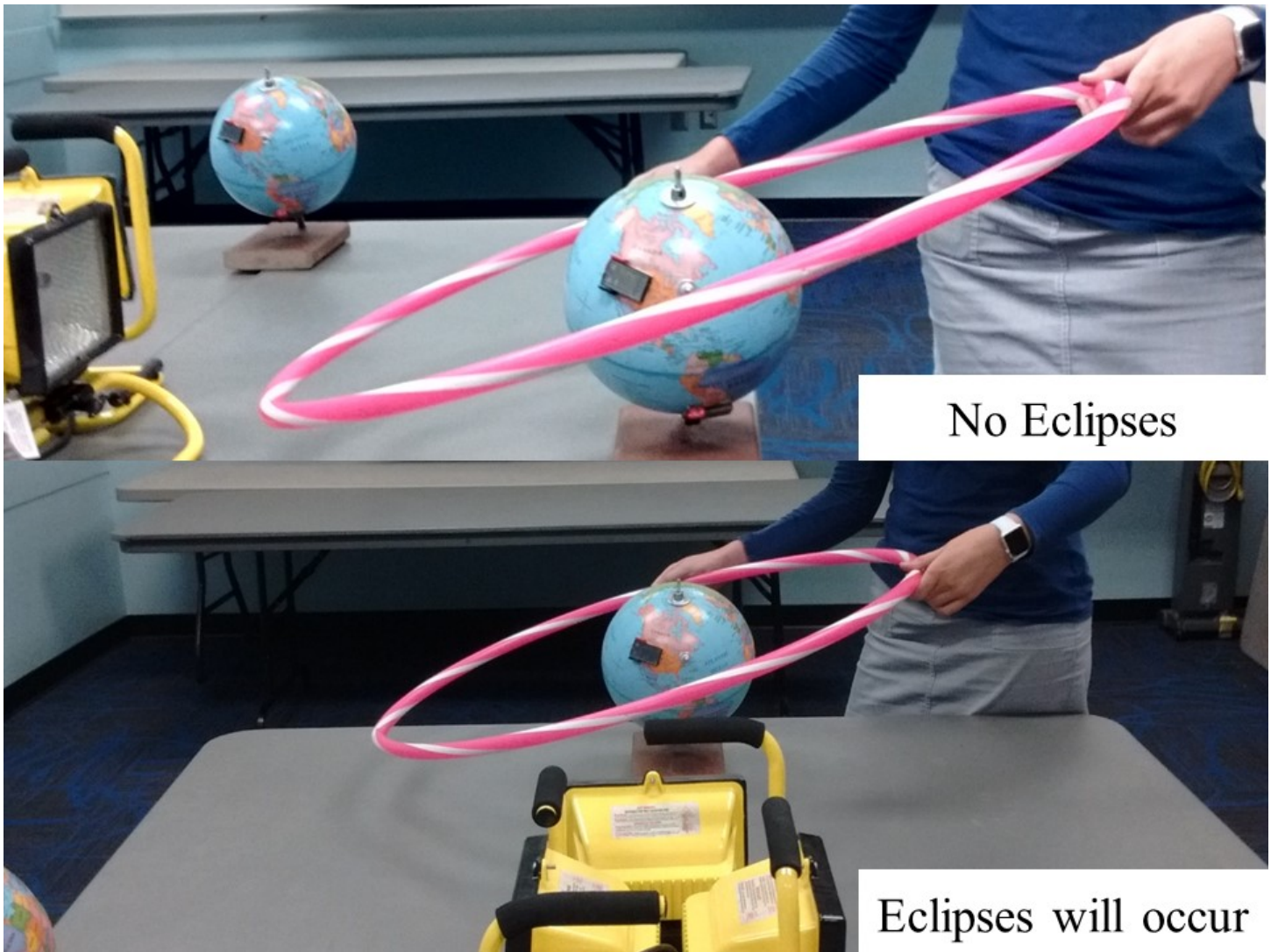

In the top image, no eclipse occurs because the moon is not on the same plane as the Earth during the full and new phases.

In the bottom picture (3 months later in our model) the moon is on the same plane as the Earth during full and new phases so eclipses do occur. Notice that the tilt and orientation of the orbit around the globe remains the same relative to the Earth.

Additional Observations:

When the Moon is between the Sun and Earth (a solar eclipse), the shadow is small and only covers part of the Earth. Would everyone on Earth be able to see the solar eclipse? Who would be able to see it? Who wouldn't?

By moving the Moon nearer or farther while creating a solar eclipse, it is possible to notice the Umbra (darkest part of the shadow) and the Penumbra (dim part of the Moon's shadow). Penumbral lunar eclipses are usually too dim to be detected by observers, even with telescopes. When the Moon is opposite the Sun in Earth's sky (a lunar eclipse), Earth's shadow covers the Moon completely (because it is MUCH larger than the Moon).



Assessment:

Use the attached worksheet.

